

OPERATOR'S MANUAL

**AQ175, AQ200, AQ225
AQ260, AQ271, AQ290, AQ311
Drives 275, 290, 290DP**

FOREWORD

Before you start using your new Volvo Penta marine engine, we recommend that you read this instruction book carefully.

Volvo Penta has built up a world-wide service organization including service workshops with specially-trained personnel at your service.

Always contact your nearest Volvo Penta representative should you need advice and also when you require service or parts.

Warranty Certificate

A warranty certificate is supplied with each new engine. It contains the warranty conditions for the engine and should be studied carefully.

Included in the warranty certificate is a report card which is to be completed by the dealer or boat seller and forwarded to Volvo Penta.

However, if our warranty is to apply, it is an absolute condition that the measures given in the "Checks and Service Scheme" are carried out and that your engine and equipment are looked after according to the instructions in this book. When in doubt, always get in touch with an authorized Volvo Penta dealer.

In all correspondence with the dealer and when ordering spare parts, state the type designation and serial number of the engine and outboard drive.

Make certain that the engine's specification coincides with what is described in this instruction book.

AB VOLVO PENTA
Technical Publications Dept.

CONTENTS

Instruments and Controls	2-3
General Information	4-5
Running Instructions	6-8
Starting the engine	6
Running instructions	7
Running in shallow waters	8
Reversing	8
Shutdown procedure	9
Checks and Service Scheme	10
Checks and Service	11-19
Check daily before starting	11
Check every 14 days	11-12
Service every 50 hours of operation	13-14
Service every 100 hours of operation	14-19
Laying-up and Launching	20-23
Propellers	24
Technical Data	27-28
Wiring Diagrams	29-31
Engine Component Guide	32-35
Fault Tracing Scheme	36
On-Board Data	37
Index, Alphabetical order	37

INSTRUMENTS AND CONTROLS

INSTRUMENT

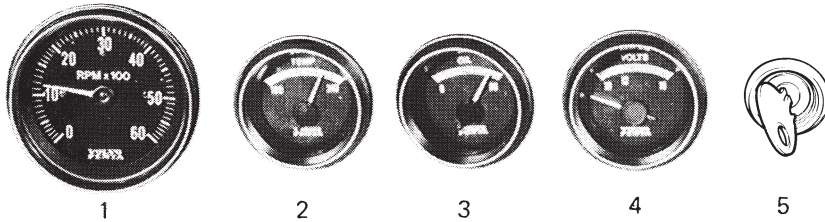

1. **Revolution counter** – graduated 0–6000 rev/min.
2. **Temperature gauge for cooling water**
Green field – normal cooling water temperature.
3. **Oil pressure gauge**
4. **Volt meter**
5. **Key-switch (for start and ignition)**

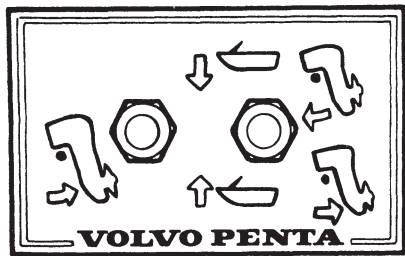

Outboard drive manoeuvring control for drive "UP" and "DOWN".

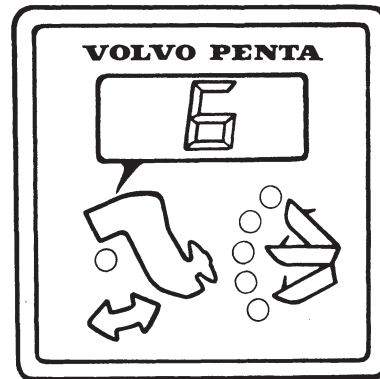

Trimming angle display.

INSTRUMENTS AND CONTROLS

OPERATING CONTROLS

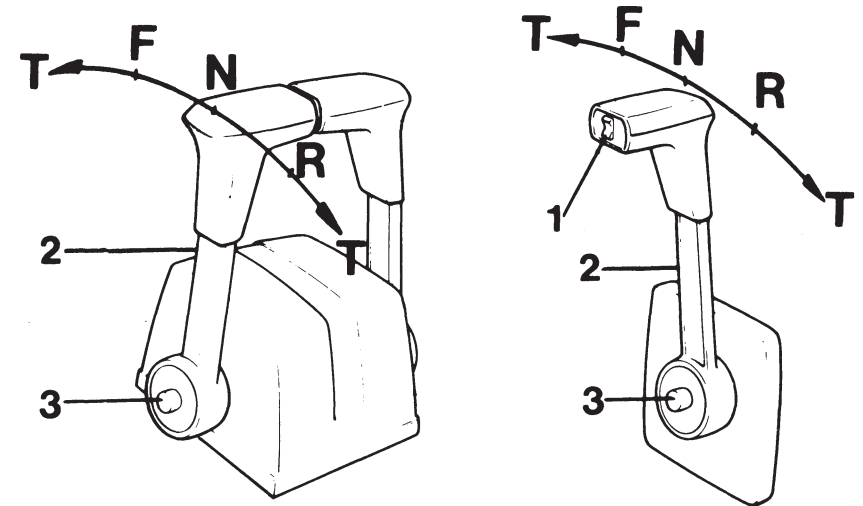

1. **Operating switch, Power Trim**
2. **Operating lever**
3. **Disengaging device**
Push in the red button when the operating lever is in neutral and move the lever forwards slightly. Release the button. The lever now operates the throttle only.
Pull back the lever when you wish to use it for operating the speed and for manoeuvring.

- N = Neutral
- F = Operating lever in position for running "Forward"
- R = Operating lever in position for "reversing"
- T = Throttle

GENERAL INFORMATION

Important information concerning the function of your engine:

- Fuel** Use petrol with 91 octane (Research Number), with or without lead.
- Lubricating oil** Use only oil with quality SE (MS) according to the API system. Volvo Penta oil for petrol engines meets the quality demands mentioned and can be used with advantage. If any other type of oil is used, see under "Technical Data", concerning the viscosity.
- Running in** A new engine must be run in with care during the first 20 hours of operation. Therefore, avoid to run the engine under full load during this period.
- Guarantee service** After approximately 20–50 hours operation or at the most 80 days after delivery your engine should be taken to an authorized Volvo Penta workshop for its free service inspection.
- Oil change** The oil in the engine and the oil filter must be replaced in connection with the service inspection after 20 hours of operation. See under "Checks and Service".

MAX. SPEED:

AQ200D, AQ225D, AQ260A,
73 r/s (4400 r/m).
AQ290A, 87 r/s (5200 r/m).

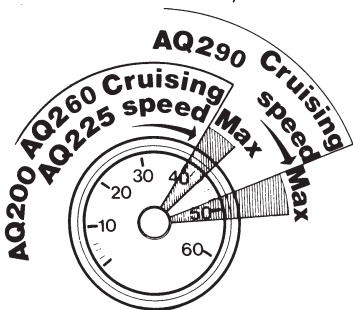

MAX. SPEED:

AQ175A 80 r/s (4800 r/m).

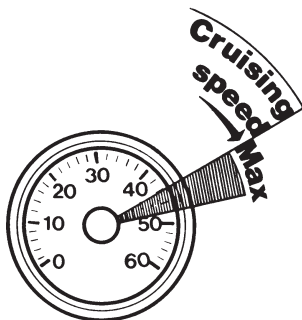

The max. permitted operating speed while cruising is 5–8 rev/sec (300–500 rev/min) below the max. speed reached.

If a propeller of the proper size is fitted and the boat has a normal load, the max. speed should lie between the above mentioned max. speed. If this speed cannot be attained, there is risk of overloading the engine. NOTE! When the boat has been in the water for some time, the boat and max. engine speed can drop due to marine growth on the bottom of the boat and the outboard drive. Try to prevent this growth on the bottom of the boat and the outboard drive with antifouling paint. See under "Measures before launching".

GENERAL INFORMATION

SAFETY EQUIPMENT

Irrespective of whether the boat is being used for long cruises or short bathing trips, it should be equipped with the safety equipment listed below. It can, of course, be supplemented further according to personal taste. Investigate at regular intervals to ensure that there is safety equipment on board and that it is in working order.

LIFE-JACKETS for all on board.

FIRE EXTINGUISHER, approved, at least one and installed easy to get at.

DISTRESS ROCKETS and matches. Packed watertight.

FIRST-AID BOX

TOOLS suitable for equipment on board.

ON BOARD KIT containing, e.g., an impeller, etc.

ANCHOR with line.

RADAR REFLECTOR

RADIO for listening to, e.g., weather reports.

COMPASS which is deviated.

BOAT HOOK and **PADDLE**.

MOORING ROPES

FOG-HORN and **WHISTLE**.

FLOATING ANCHOR

TORCH

PROPELLER

PREPARATIONS BEFORE STARTING

Before starting make sure that:

There is no **FUEL LEAKAGE**

There is no **WATER LEAKAGE** from engine and hull

There is no **OIL LEAKAGE**

There is no **SMELL OF LP-GAS** in the deep cavities of the boat or elsewhere

The **OIL LEVEL** is correct

The proper **NAUTICAL CHARTS** are on board for the planned voyage.





There is enough **FUEL** on board for the planned voyage.

Make sure when filling with fuel that there is no naked flame on board, e.g., in the galley. Ventilate the boat and run the engine room fan (if fitted) before starting the engine. Do not fill with too much fuel.

If some people are on board for the first time, tell them how to manovre the boat and where to find the life-jackets and the fire-extinguisher. Also tell them everything else you think necessary from the point of view of safety. Should something unexpected happen during the voyage, very often it is too late to tell those on board how the safety equipment works.

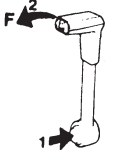

RUNNING INSTRUCTIONS

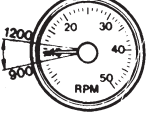
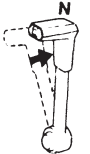
STARTING THE ENGINE

	<p>Switch on the main switch. Start the engine room fan (if fitted) and allow it to run for several minutes before starting the engine.</p>
	<p>Lower the drive, if it has been tilted. Make sure there is no obstacle near the propeller.</p>
	<p>To use the control lever for throttling only, proceed as follows: Move the control lever (2) to neutral, push in the red disengaging button (1), and move the lever slightly forwards. Release the button. The lever now only operates the throttle.</p>
	<p>Turn the key switch one step to the right. Push in and turn the key further to the right to start the engine. Release the key as soon as the engine has started. If in cold weather the engine is reluctant to start the key should be turned back to the off position after each start attempt and a pause made between each attempt.</p>
	<p>Check immediately after starting that the oil pressure gauge and the voltmeter show normal values. If abnormal values are shown the engine must be stopped immediately and the cause investigated.</p>
	<p>Run the engine warm at high idling speed which means 15–20 r/s (900–1200 r/m).</p>
	<p>Set the speed at idling and check that the engine runs smoothly. Pull the lever to neutral. The control lever now operates the power transmission as well as the throttle simultaneously.</p>

RUNNING INSTRUCTIONS

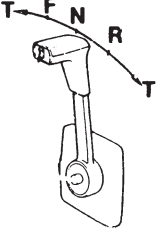
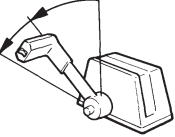
RUNNING INSTRUCTIONS

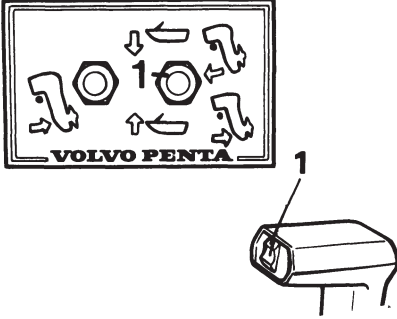

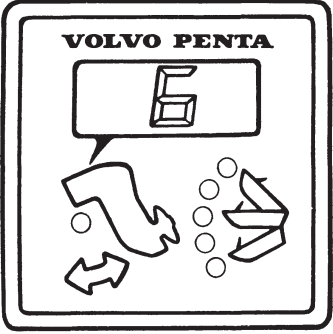
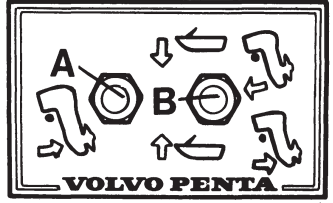
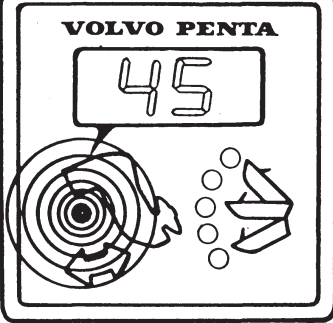
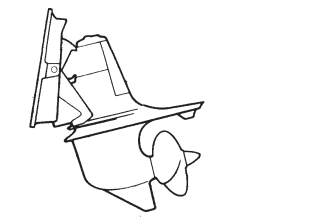

	<p>The single control lever operates both the speed and the power transmission. F = Forward R = Reverse N = Neutral T = Throttle</p>
	<p>To obtain good operating economy the engine should not be run at maximum speed for longer periods. Note that the maximum operational speed for longer periods, the so called "cruising speed" is 300–500 r/m less than the maximum of speed obtained.</p>
	<p>Check that the engine temperature is normal when running (the needle is within the green field) and that the instruments for charging and oil pressure show normal values. If abnormal values are shown the engine must be stopped immediately and the cause investigated.</p>
	<p>The outboard drive unit can be trimmed in or out via the hydraulics system. To drop the bow of the boat press down one of the switches (1) (on the manoeuvring control lever and on the instrument panel) until the level desired is achieved. To raise the bow of the boat hold the switch (1) in the upper position. WARNING! Do not under any circumstances activate the two switches (1) simultaneously.</p>

RUNNING INSTRUCTION

	<p>The drive is adjustable within the trimming range to obtain the best running angle. For the 290 drive the maximum trimming angle is 12.</p>
	<p>Operating in shallow water. When uncertain about the depth of water under the boat slow down to idle speed and raise the drive. Press down the button (A) at the same time as the control button (B) is held in the up position. The drive can now be raised to a maximum of 44. At 45 the red indicator light on the instrument will begin to flash. The positions over 45 are only for use when the boat is moored in shallow water or when it is being transported on a trailer.</p>
	
	<p>Reversing Reversing can be carried out with the drive raised to a maximum of 44. IMPORTANT! Never reverse when the boat is planing.</p>

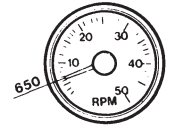
RUNNING INSTRUCTIONS

SHUTDOWN PROCEDURE

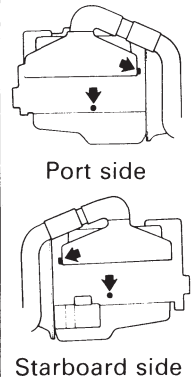
	<p>Before stopping the engine it should be allowed to idle for a minute or two with the control lever in neutral.</p>
	<p>Stop the engine by turning the key back to the switched-off position.</p>
	<p>If there is shallow water at the mooring place and if there is risk that the drive can strike the bottom, it should be fully tilted. Otherwise it is not necessary to tilt the drive.</p>
	<p>Switch off the main switch. IMPORTANT! The main-switch must never be switched off until the engine has stopped.</p>
 <p>Port side</p> <p>Starboard side</p>	<p>Before leaving the boat check that there is no water leakage. If cold weather and risk of icing, drain the cooling water from the engine. The cooling water is drained through the plugs on the engine block and the exhaust manifold. Also loosen the cover on the seawater pump. NB! Close the cocks and tighten the cover before leaving the boat.</p>

Protect your boat and make theft difficult. Never leave your boat ready for use.

CHECKS AND SERVICE SCHEME

Checks and servicing should be carried out regularly according to the intervals given below. Let an authorized Volvo Penta Service Workshop maintain your engine.

CHECK DAILY BEFORE STARTING that

The engine oil level is between the marks on the dipstick	Page 11
---	------------

CHECK every 14 days that

The oil level in the drive is between the marks on the dipstick	11
Oil level in the hydraulic pump (Power trim)	11
The electrolyte level in the battery is correct	12
The belt tension is sufficient to prevent the alternator from slipping	12
The zinc-rings has not been reduced more than 50 %	12

SERVICE EVERY 50 HOURS OF OPERATION

Change the oil in the engine	13
Lubricate the steering shaft journals	13
Spark plugs. Check and if necessary replace	14

SERVICE EVERY 100 HOURS OF OPERATION OR AT LEAST ONCE PER SEASON:

Change the oil filter	14
Change the oil in the drive (every 200 hours)	14
Check the drive belt for the alternator and circulation pump	15
Check the ignition system	15
Check and adjust the carburettors	16
Check the cooling system	17
Check/replace the impeller	18
Electrical system. Check. Fusing. Battery	19

MEASURES IN CONNECTION WITH LAYING UP AND LAUNCHING THE BOAT

Inhibiting. Carried out with boat on land	20
Launching	22

CHECKS AND SERVICE

CHECK DAILY BEFORE STARTING

OIL LEVEL IN ENGINE

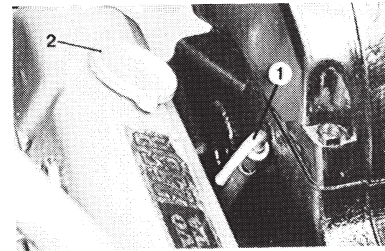

Check the oil level daily before starting and make sure that the oil level is within the marked field on the dipstick (1). Fill with oil when necessary through the oil filler (2). NOTE! Do not exceed the maximum mark. See "Technical Data" for choice of oil.

CHECK every 14 days

OIL LEVEL IN DRIVE

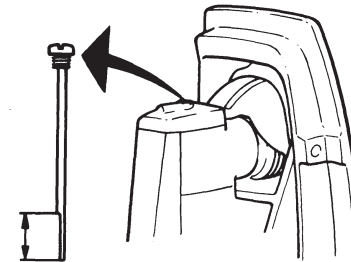

Check the oil level with the drive fully down. The oil level should be between the marks on the dipstick, which must not be screwed down when measuring the oil level. Make sure that water cannot enter the drive while carrying out the oil-level check. If necessary, top-up with oil through the hole for the dipstick. Concerning the type of oil, see under "Technical Data".

NOTE! The O-ring which lies in the groove under the dipstick tightening screw.

OIL LEVEL IN THE HYDRAULIC PUMP (POWER TRIM)



Trim the drive as far in as possible. Remove the screw and check that the pump is filled with oil. Top up if needed, the oil should be level with the filler hole. For the correct oil type check in "Technical Data". When checking the oil level great care should be taken to prevent any dirt or other matter entering the system.

CHECKS AND SERVICE

ELECTROLYTE LEVEL IN BATTERY

The level should be 5–10 mm (3/8") above the cell plates in the battery. If necessary, top-up with distilled water. CAUTION! Observe great care since the gas formed in the battery is explosive and the acid corrode.

BELT TENSION

The V-belt must be properly tensioned in order to get full alternator output and correct cooling water temperature. The V-belt is properly tensioned when it is possible to depress it 10 mm (3/8") midway between the pulleys.

For correct V-belt tension see page 17 "Check the V-belts".

CORROSION PROTECTION

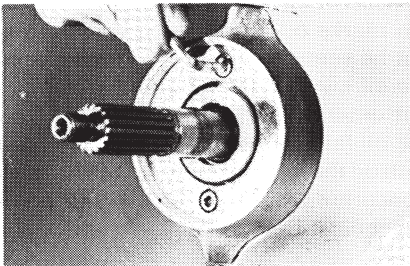

Replace the zinc ring on the inside of the propeller when it has been worn down by 50 %. See "Removing and installing the propeller".

Make sure that the contact surface on the drive is clean before fitting the new zinc ring.

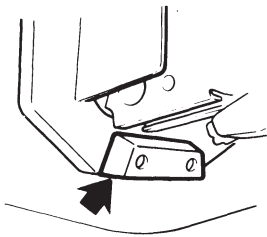

Change the zinc plate under the shield when it has been corroded to half its normal size.

Scrape the area for mounting clean before fitting the new zinc plate.

CHECKS AND SERVICE

SERVICE EVERY 50 HOURS OF OPERATION

CHANGE OIL IN ENGINE

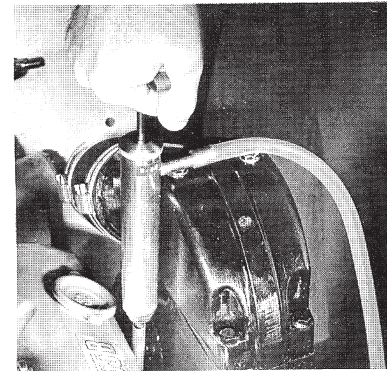

The oil is to be changed in new or re-conditioned engines after the first 20–50 hours of operation and then after every 50 hours of operation.

Run the engine until it is hot. Suck up the oil through the tube for the dipstick.

Fill up with oil to the correct level. See "Technical Data" for choice of oil.

NOTE! The oil filter must also be changed at every other oil change.

LUBRICATING THE STEERING SHAFT JOURNALS



Grease the steering shaft journals with a grease-gun until grease is forced out at the journals. Use water-resistant grease.

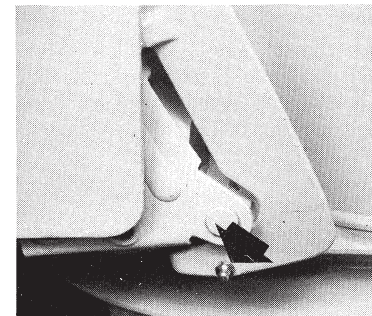

Grease the lower steering shaft journal with a grease-gun until grease is forced out at the journal. Use water-resistant grease.

CHECKS AND SERVICE

SPARK PLUGS

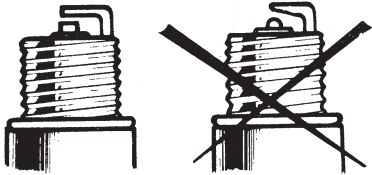

Check the electrode gap and adjust if necessary. If the spark plugs are damaged or worn, or the edges of the electrodes rounded the spark plugs must be replaced with those with similar data. See under "Technical Data".

**SERVICE EVERY 100 HOURS OF OPERATION
OR AT LEAST ONCE PER SEASON**

OIL FILTER

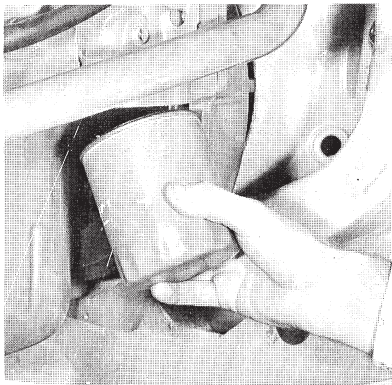

The oil filter is to be changed the first time after 20 hours of operation and then after every other oil change. Screw off the old oil filter. **Be careful not to spill oil.**

Coat the rubber seal of the new filter with oil. Check the contact surface on the engine and screw on the filter **by hand** until it touches the contact surface. Turn the filter a further **half turn, not more.**

NOTE! Use only genuine Volvo Penta oil filters.

Start the engine, run at idling speed and check immediately that the oil pressure gauge shows normal values.

Check the oil-level and check also for leakage around the filter.

OIL CHANGE IN DRIVE (every 200 hours)

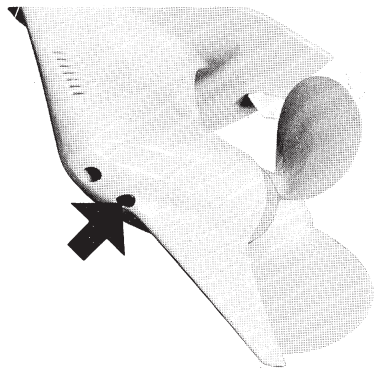

Draining

Remove the oil dipstick. Tilt the drive. Remove the plug under the propeller gear housing and let the oil run out. Refit the plug with its O-ring.

CHECKS AND SERVICE

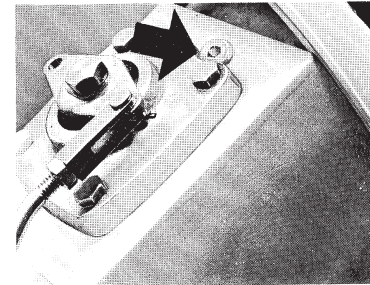

Filling

Remove the oil filler plug. Fill up with oil. Concerning the quality of the oil and capacity see under "Technical Data". Refit the plug together with its O-ring. Tilt down the drive. Check the oil with the dipstick, which must not be screwed down when measuring the level. Fill up to the correct level through the dipstick hole. If the level is too high, the oil must be drained to the correct level. Re-insert the dipstick together with its O-ring.

Check that the drain-plug is not leaking.

CHECKING AND REPLACEMENT OF V-VELTS

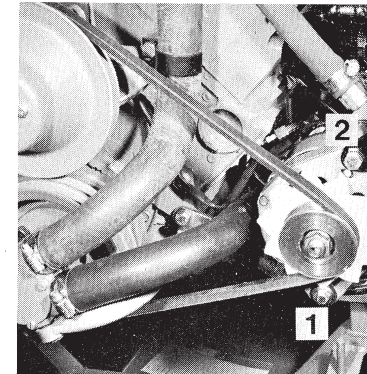

Check the belt thoroughly for wear and cracks. Any indication of such and the belt must be replaced. Loosen the alternator mounting bolts 1 and 2 and slip off the belt. Clean the belt grooves on the pulley before fitting the new belt. Tension the belt in such a way that it can be depressed 10 mm (3/8") between the pulley. After a few hours of running re-check the belt tension and adjust if necessary.

IGNITION SYSTEM

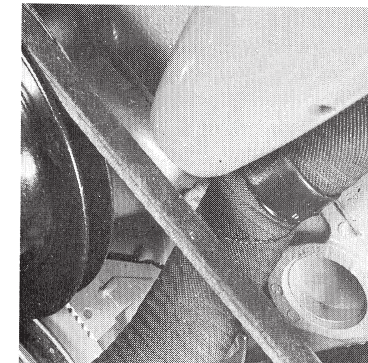

All adjustments to the engine ignition system should be handed over to an authorized workshop which has the necessary equipment for this kind of work. The ignition system is sensitive and faulty handling can easily cause serious damage.

The distributor should be checked in a test bench. The ignition timing is checked by means of a stroboscope. Regarding the setting values, see under "Technical Data".

Lubricate the distributor with a few drops of engine oil in the drive shaft lubricating wick under the rotor.

CHECKS AND SERVICE

CARBURETOR

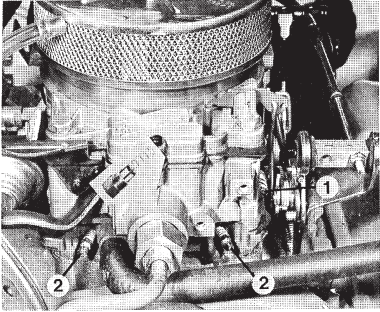

4-port carburetor (AQ225D, AQ260A and AQ290A)

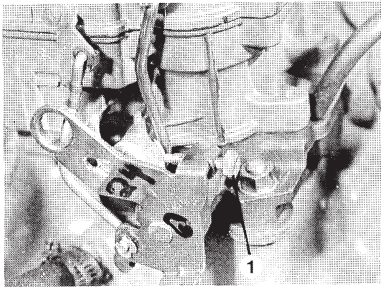

2-port carburetor (AQ175A, AQ200D)

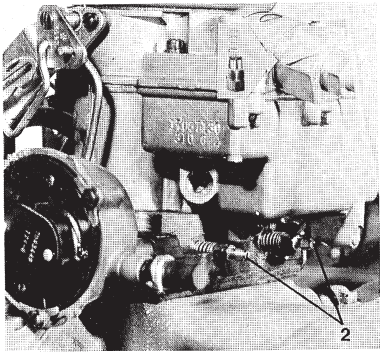

2-port carburetor (AQ175A, AQ200D)

A correctly adjusted carburetor is imperative for good operation and fuel economy. For this reason you should let an authorized workshop check the adjustment sometimes during the season.

Idling adjustment is carried out as follows:

1. Run the engine warm to the correct operating temperature, until the choke has fully opened.
2. Adjust the idling speed (see "Technical Data") with the idler screw (1).
3. Adjust the air/fuel mixture with the air screws (2) so that the best and quietest idling speed is obtained. Screw in first until the engine begins to run unevenly and then screw out until the best idling speed is obtained. Adjust afterwards with the idler screw if necessary. Check the air cannot leak between the carburetor and the induction pipe since this can lead to an increase in engine speed.

Fuel filter at the carburetor

The carburetor is fitted with a fuel filter positioned at the fuel pipe's connection to the carburetor.

The filter should be checked once each season or when necessary

Check: Undo the fuel line and remove the nipple in the filter housing (watch out for spilling fuel). The filter can now be removed and checked (wash where required in solvent or similar product). Note the spring inside. Refit in the reverse order. The filter's closed end is to face the spring. Check that the seal between the nipple and the filter housing is not damaged. Start the engine after reassembly and check that the connections do not leak.

CHECKS AND SERVICE

Fuel filter by the fuel pump

The filter insert is to be changed once every season or after every 100 hours. Screw out the filter housing, replace the old filter insert with a new one and screw the filter housing tight. Watch out for spilling fuel.

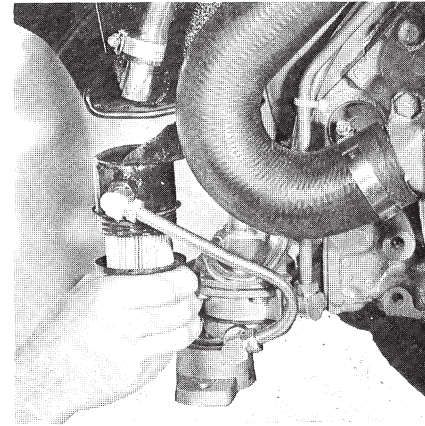

CHECKING AND REPLACING THE IMPELLER

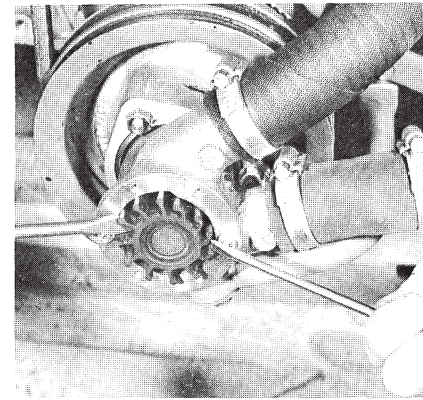

The pump impeller can be damaged through lack of water. Remove the cover from the water pump. Inspect the impeller. If it is damaged it must be replaced. Remove it with the help of two screwdrivers. Do not damage the housing.

CHECKING THE COOLING SYSTEM

The temperature gauge for cooling water has a green range which corresponds to normal cooling water temperatures in the engine. The cooling system must be checked and investigated if the temperature is abnormal.

If the temperature is abnormal have the engine looked at by an authorized Volvo Penta workshop.

CHECKS AND SERVICE

ELECTRICAL SYSTEM

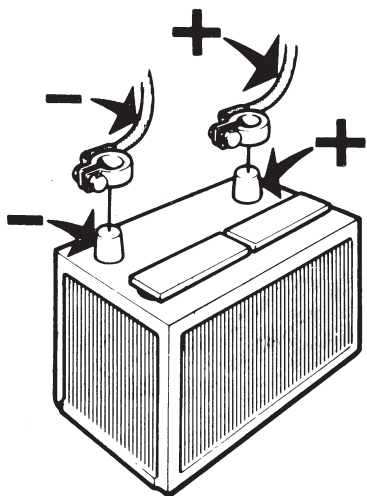
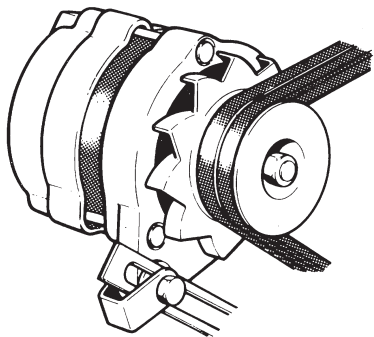

Alternator

The engine is equipped with an alternator. If the alternator and the regulator are to function without interference, it is important that the following instructions are observed:

1. **The main switch must not be switched off until the engine has stopped. Otherwise the charging regulator can be ruined.**

2. **Battery terminals polarity must never be mixed up.** The battery terminals have a plus and a minus sign respectively. The cable from the minus terminal is connected to the engine block. The cable clamps must be greased and well tightened.

3. **Do not switch between the charging circuits while the engine is running.**

Fit the Volvo Penta charging distributor (accessory) to the alternator when more than one battery is connected.

4. In the event the engine has to be started with the help of a spare battery, proceed as follows:

Let the ordinary battery remain connected. Connect the spare battery to the ordinary battery with plus to plus and minus to minus. When the engine has started, remove the spare battery but under no circumstances may the circuit to the ordinary battery be broken.

5. Don't use a rapid charger when the alternator is connected to the battery.
6. Disconnect both battery cables before doing any work on the alternator equipment.
7. Before carrying out any electrical welding on the engine or installation parts, disconnect the charging regulator cables at the alternator and insulate the cable ends.
8. Check the belt tension and the cable connections regularly.

CHECKS AND SERVICE

Reset button on fuse

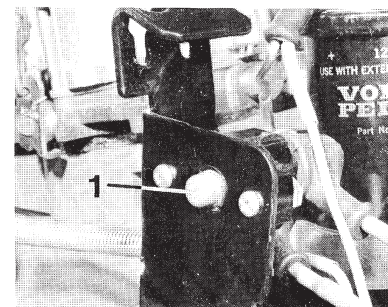

The engine is equipped with an automatic fuse which breaks the electrical system when overloaded. The automatic fuse has a re-set button (1). Always investigate the reason for the overload.

Fuses in the electrical system

The engine is equipped with two replaceable 8A fuses at the instrument panel. Always carry spare fuses.

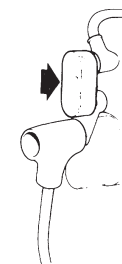

Fuses in the electrical system (Power Trim)

The electrical system for Power Trim has a 80A fuse at the starter motor, (see fig) and a 5A fuse at the control.

Checking of starter motor and alternator

Let an authorized service-workshop do all checking and repairs of the starter-motor and the alternator. Inspection and control should be carried out in connection with a general inspection of the engine.

BATTERY

Checking the charging status

The charging status of the battery should be checked at least once each season. The check is carried out using a hydrometer which indicates the specific gravity of the electrolyte, this varying with the status of the charging, (see "Technical Data").

LAYING-UP AND LAUNCHING

SERVICE AND CONNECTION WITH LAYING-UP AND LAUNCHING THE BOAT

INHIBITING

IDLE ENGINE FOR BRIEF PERIODS WITH BOAT IN WATER

To prevent the engine from corrosion, it must be run warm at least once every 14 days as long as the boat is in the water. If it is anticipated that the boat will not be used for longer periods, long-term inhibiting should be carried out.

INHIBITING WHEN LAYING UP FOR THE WINTER



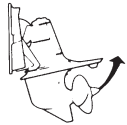
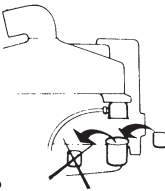
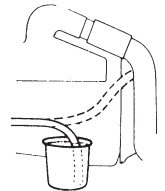

An authorized service shop should test the engine and equipment before inhibiting the engine for a long period. It is advisable to test the compression to find out the condition of the engine.

Inhibiting scheme

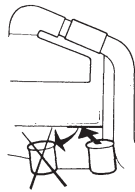

Carried out with the boat on land

 <p>1</p>	<p>When transporting the boat on a trailer for example, the outdrive must be fully tilted.</p>
 <p>2</p>	<p>Change the fuel filter. (See page 17).</p>
 <p>3</p>	<p>Loosen the hose at the transom shield and put the free end into a container with fresh water. Arrange for refilling of the container.</p>

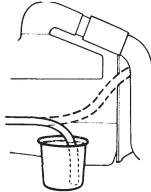

LAYING-UP AND LAUNCHING

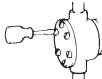
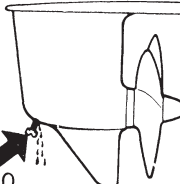
 <p>4</p>	<p>Let the engine run on fast idling for a few minutes. Then stop the engine. Drain the system. Check that the vicinity of the exhaust outlet is not being splashed. NOTE! The pump must not be allowed to run dry. Do not let the propeller rotate.</p>
 <p>5</p>	<p>Pump out all oil from the engine. Use the oil drainage pump.</p>
 <p>6</p>	<p>Change the oil filter. Fill up the engine to the correct level with Volvo Penta engine oil, which also has corrosion protective properties. After this the engine is ready to run on this oil next season. By long-time inhibiting, exceeding a normal winter laying-up, preservative oil must be used. This should be of the type Esso Rustban 623, Shell Ensio Oil or corresponding oil. In this case the oil filter shall not be replaced until launching.</p>
 <p>7</p>	<p>Mix a 20 % rust-proofing mixture containing fresh-water and emulsifying, rust-proofing oil. NOTE! Water first, than oil. Use e.g. Esso Cutwell 40, Shell Donax C or similar.</p>
 <p>8</p>	<p>Insert the hose into the rust-proofing mixture. Start the engine and let it run idle until the mixture is finished. NOTE! The pump must not be allowed to run dry.</p>

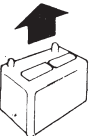

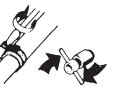

LAYING-UP AND LAUNCHING

 <p>9</p>	<p>The rust-proofing mixture does not have anti-freeze properties, therefore it has to be drained off the engine. Draining points see page 9. Remove the cover from the seawater pump. Check that the impeller is undamaged. Refit the cover.</p> <p>NOTE! Do not remove the impeller if undamaged. Reconnect hoses which have been removed.</p>
 <p>10</p>	<p>Loosen the oil drain-plug of the bottom of the outdrive to let out a few drops of oil. Check that the oil is clean and not discoloured.</p> <p>Further inhibiting of the outdrive is not necessary. Remove the propeller and coat the shaft with rust-proofing oil.</p>
 <p>11</p>	<p>Clean the outside of engine and drive. Touch-in any bare patches in the paintwork with the original type of paint. Spray the components of the electrical system, and all the control components with anti-moisture spray.</p>
 <p>12</p>	<p>Remove the battery. For proper maintenance it needs to be charged to prevent it from being damaged.</p>

MEASURES IN CONNECTION WITH LAUNCHING

 <p>13</p>	<p>If Volvo-Penta oil has been used in the engine only the level needs to be checked.</p> <p>If another type of inhibiting oil has been used, both the oil and the filter must be changed. See under "Service every 50 hours of operation".</p>
 <p>14</p>	<p>Check the drive oil level. If it is too high, it must be lowered by draining. If it is too low, top-up through the hole for the oil dipstick. NOTE! The dipstick must not be screwed down when checking the oil level. Check also the oil level in the hydraulic pump (Power Trim). Fill if necessary.</p>
 <p>15</p>	<p>Check the tightening of all hose-clamps. Check that all drain-cocks are closed. Clean the engine and drive on the outside. Check the exhaust-hose.</p>

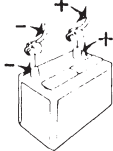
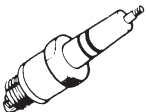
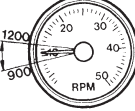
LAUNCHING

 <p>16</p>	<p>Check carefully the rubber bellows for damage and check the tightening of the hose-clamps. NOTE! The bellows over the U-joint and the clamps should be replaced each 2nd year. If the drive has been removed be careful to refit bellows and hose clamps in the right position. Check the retaining pawl, see page 25. Fit the propeller. Check the tightening of the Allen-bolt which attaches the steering-helmet to the drive. Tightening torque – see "Technical Data".</p>
 <p>17</p>	<p>Examine the paintwork on the outboard drive. Touch up any blemishes with genuine Volvo-Penta paint. Then paint the drive with Volvo-Penta anti-fouling paint. Important! Anti-fouling paint containing copper must not be used, since this can corrode the drive. Launch the boat once the paint has dried.</p>
 <p>18</p>	<p>Install the battery or batteries, which must be fully charged. Grease the cable shoes. Connect up the battery cables. Important! Do not mix up the polarity. Tighten the cable shoes well.</p>
 <p>19</p>	<p>Remove the spark plugs. Make sure nothing gets splashed with oil and turn over the engine several revs in order to blow out any oil on top of the pistons. Note! The drive must be fully down.</p> <p>If necessary, fit new spark plugs. See under "Technical Data".</p>
 <p>20</p>	<p>Start the engine. See instructions on page 6. Run the engine warm with gear engaged, if this is possible. Check and make sure there is no fuel leakage, no water leakage or exhaust gas leakage. Check further that the manoeuvring functions are in order.</p>
 <p>21</p>	<p>When necessary, contact an authorized Volvo-Penta service workshop. Let them service your engine and drive according to the instructions given in the servicing scheme.</p>

PROPELLER

SELECTING THE RIGHT PROPELLER

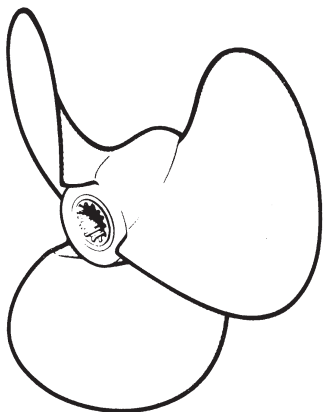

The right propeller has been selected when the engine maximum speed is reached with a normal load in the boat.

A left-hand rotating propeller should be selected for single installation, since with this direction of rotation there is less tendency for the boat to deviate from course.

With a twin installation, the port drive should be adjusted for a left-hand rotating propeller and the starboard drive for a right-hand rotating propeller.

When replacing a propeller, make sure that you get a genuine Volvo Penta propeller of the same size as the old propeller. The size is punched on the propeller hub. Sizes are given in inches, e.g., 15 x 17, where 15 stands for the diameter and 17 for the pitch.

AQ290

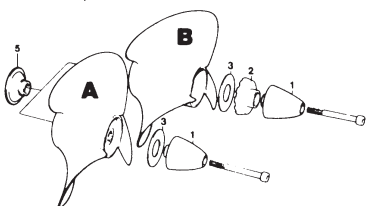

Fitting a long-hub propeller (A)

1. Spread a thin layer of grease on the prop shaft.
2. Fit the anti-fouling protector.
3. Fit the propeller.
4. Slip on the plastic washer (3).
5. Fit and tighten the propeller cone (1).
6. Fit and tighten the centre screw.

Fitting a short-hub propeller (B)

1. Spread a thin layer of grease on the prop shaft.
2. Fit the anti-fouling protector.
3. Fit the propeller.
4. Slip on the plastic washer (3).
5. Fit the spacer ring (2).
6. Fit and tighten the propeller cone (1).
7. Fit and tighten the centre screw.

TRIMMING THE DRIVE

ADJUSTING THE REVERSING TIE ROD

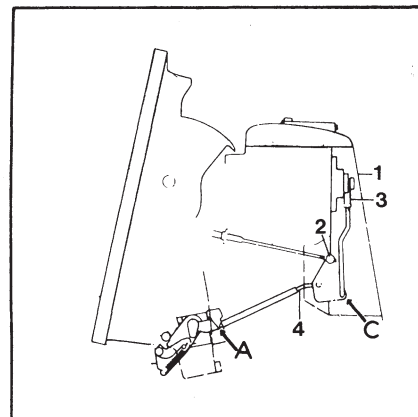

1. Remove the cover (1). Set the manoeuvring control lever in the neutral position.
2. Disconnect the gear cable's coupling bushing (2) and the linkage (3).
3. Remove the locking nut from the fork (3). Adjust the fork so that when connected to the actuating arm the reversing tie rod (4) reaches the reverse catch facing at "A" without forcing. Lock the fork (3) with the lock nut.
4. Adjust the coupling bushing (2) so that it fits easily into the gear yoke. Move the manoeuvring lever to the "forward" position. Check that the corner "C" does not catch in the housing. Refit the cover (1).

TRIMMING THE DRIVE

ADJUSTING COURSE DEVIATION

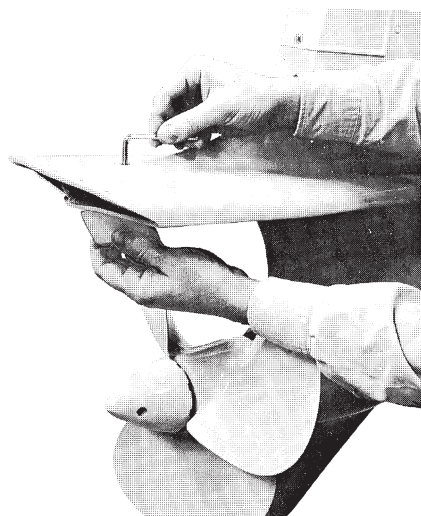

Check for deviation in course by releasing the wheel when the boat is planing and observe its course. If, e.g., the boat veers to port, the trim tab under the cavitation plate on the drive must be loosened. Then turn the rear edge of the trim tab slightly to port and lock the trim tab in this position. Test-run the boat. Adjust the trim tab further if the boat still tends to veer.

TECHNICAL DATA

General

Type designation	AQ175A	AQ200D AQ225D	AQ260A AQ290A
Type of engine	4-stroke	4-stroke	4-stroke
Number of cylinders (2 banks, 90° V-form)	6	8	8
Output, see sales literature			
Bore, mm (in)	95 (3.75)	95 (3.75)	101.6 (4.0)
Stroke, mm (in)	88.4 (3.48)	88.4 (3.48)	88.4 (3.48)
Capacity, dm ³ (cu.in.)	3.8 (229)	5 (305)	5.74 (350)
Compression ratio	8.6:1	8.5:1	8.5:1 (AQ290 9:1)
Compression pressure (starter motor)	10–11 kp/cm ² (142–156 p.s.i.)		
Max. operating speed, long running periods (cruising speed), rev/sec	5–8 (300–500 r/m) lower than max. speed obtained		
Idling speed rev/sec	10.0–10.8 (600–650 r/m)		
Direction of rotation, viewed from rear	Counter clockwise		
Max propeller, diameter	16"		
Total weight, engine risers and outboard drive, approx. kg. (lbs)	340 (748)	410 (900)	410 (900)
Outboard drive	290B	290B	290B
Ratio	1.61:1	1.61:1	1.61:1

Valves

Valve system	Overhead		
Valve clearances	Hydraulic valve lifters (no valve clearance adjustment necessary)		

Cooling system

Thermostat limit values, °C (°F)	62–72 (153–160)		
----------------------------------	-----------------	--	--

Lubricating system

Engine	Service SE		
Oil grade	SAE 10W/30 or 10W/40		
Oil viscosity	3.8/4.0	–	–
Oil capacity excl. oil filter, litres/US.qts.	–	–	–
Oil capacity excl. oil filter, litres/US.qts. (AQ200D)	–	4/4.2	–
Oil capacity excl. oil filter, litres/US.qts. (AQ225D)	–	5/5.3	–
Oil capacity excl. oil filter, litres/US.qts.	–	–	5/5.3
Oil capacity incl. oil filter, litres/US.qts.	4.1/4.3	–	–
Oil capacity incl. oil filter, litres/US.qts. (AQ200D)	–	4.4/4.7	–
Oil capacity incl. oil filter, litres/US.qts. (AQ225D, AQ260A)	–	5.4/5.7	5.4/5.7
Oil capacity including oil filter and oil cooler litres/US.qts.	–	–	5.6/5.9
Oil capacity between max. and min. litres/US.qts.	1.0/1.0	1.0/1.0	1.0/1.0

TECHNICAL DATA

Outboard drive

Oil grade/viscosity	Same as engine
Oil capacity, approx. litres/US.qts.	2.6/2.7
Oil capacity between max. and min. marks on the dipstick, liter.	0.15
Oil capacity, hydraulic system power trim, litres/US.qts.	0.52
Oil grade/viscosity	Same as engine

Ignition System (V6)

Firing order.	1-6-5-4-3-2
Basic setting.	10° B.T.D.C.
Stroboscop setting, 4200 rpm.	34° B.T.D.C.
Distributor, contact gap, mm (in).	0.43-0.56
Dwell angle.	33°-37°
Spark plugs	VP Part no 835269-2
Spark plugs, electrode gap, mm (in)	0.7 (0.028")

Ignition system (V8)

Firing order.	1-8-4-3-6-5-7-2
Basic setting (idling speed)	8° B.T.D.C.
Ignition distributor, contact gap, mm.	0.36-0.48 (.014-.019")
Ignition distributor (AQ290) contact gap, mm.	0.25-0.36 (.010-.014")
Dwell angle.	31°±3°
Dwell angle (AQ290)	31°+1° -2°

Spark plugs	VP Part no 835269-2
Spark plugs, electrode gap, mm	0.7 (0.028")

Electrical system

Voltage, V	12 V Negative Ground
Battery, capacity, standard, Ah.	60
Battery electrolyte specific gravity:	
Fully charged battery.	1.275-1.285
When re-charging is necessary	1.230
Generator, type	Alternator
Output, max. A(W)	50 (50x14)
Starter motor	
Output kW (hp)	0.96 (1.3 hp)

Tightening torques:

Cylinder head bolts, Nm (kpm)	90 (9)
Spark Plugs	21 (2,1)
Steering helmet bolts	35 (3,5)

WIRING DIAGRAM

INSTRUMENT PANEL

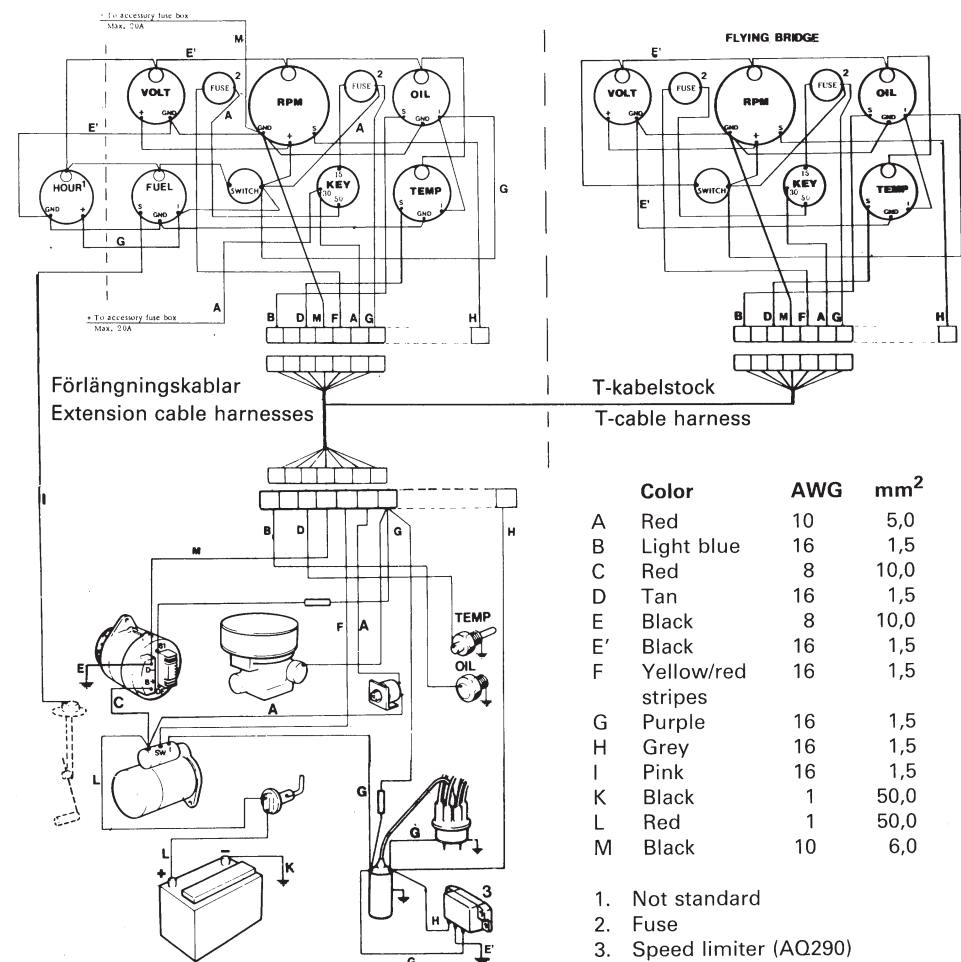

ENGINE COMPONENT GUIDE

AQ200D/290
 AQ225D/290
 AQ260A/290
 AQ290A/290

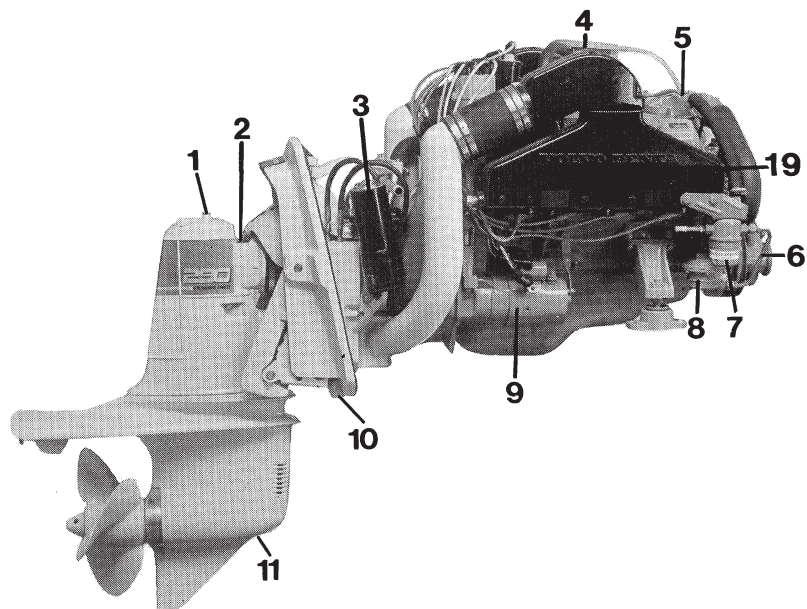

AQ200D/290
 AQ225D/290
 AQ260A/290
 AQ290A/290

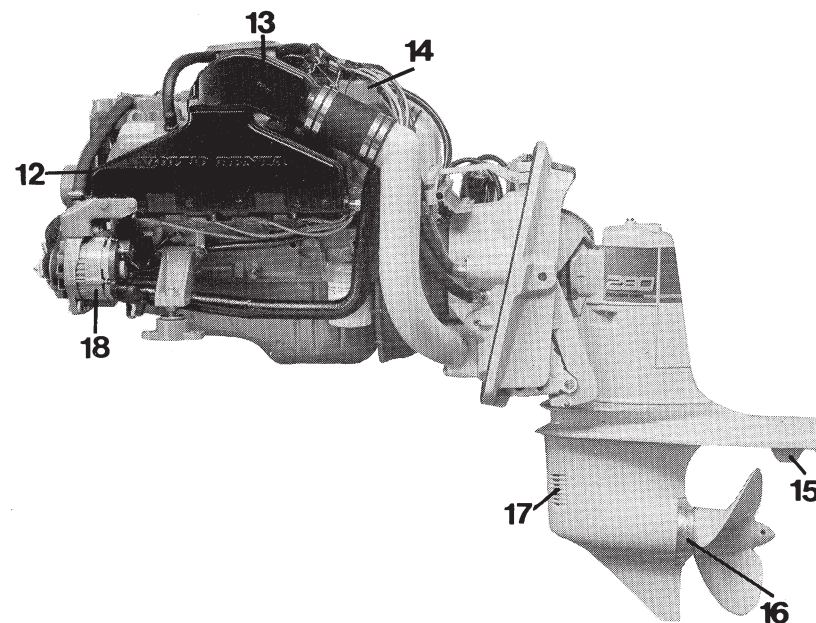

- | | |
|---|---------------------------|
| 1. Oil dipstick, outboard drive | 9. Starter motor |
| 2. Serial number and data plate. | 10. Anti-corrosion device |
| 3. Hydraulic pump (Power Trim) | 11. Oil drain, drive |
| 4. Down draft carburetor with flame arrester AQ200D, 2-port carburetor AQ225D, AQ260A, AQ290A 4-port carburetor | 12. Circulation pump |
| 5. Thermostat and distribution housing | 13. Risers |
| 6. Seawater pump | 14. Distributor |
| 7. Fuel filter | 15. Trim tab |
| 8. Fuel pump | 16. Zinc-ring |
| | 17. Cooling water intake |
| | 18. Alternator |
| | 19. Serial number, engine |

Explanations, see page 32.

ENGINE COMPONENT GUIDE

AQ175A/290

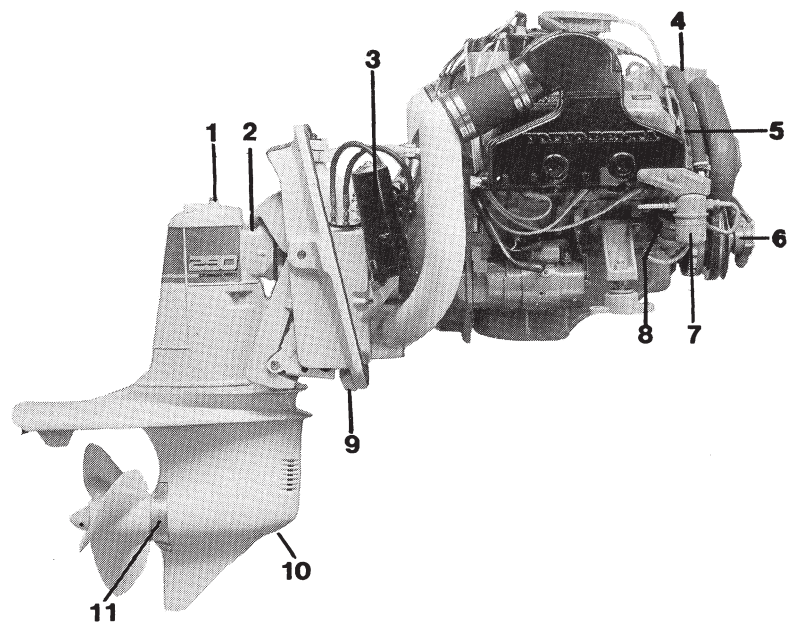

- | | |
|--|----------------------------|
| 1. Oil dipstick, outdrive | 8. Fuel pump |
| 2. Serial number and type designation, outdrive | 9. Zinc anode |
| 3. Hydraulic pump (Power Trim) | 10. Oil drainage, outdrive |
| 4. Thermostat and cooling water distribution housing | 11. Zinc anode |
| 5. Serial number, engine | 12. Carburettor |
| 6. Raw water pump | 13. Ignition coil |
| 7. Fuel filter | 14. Cooling water intake |

ENGINE COMPONENT GUIDE

AQ175A/290

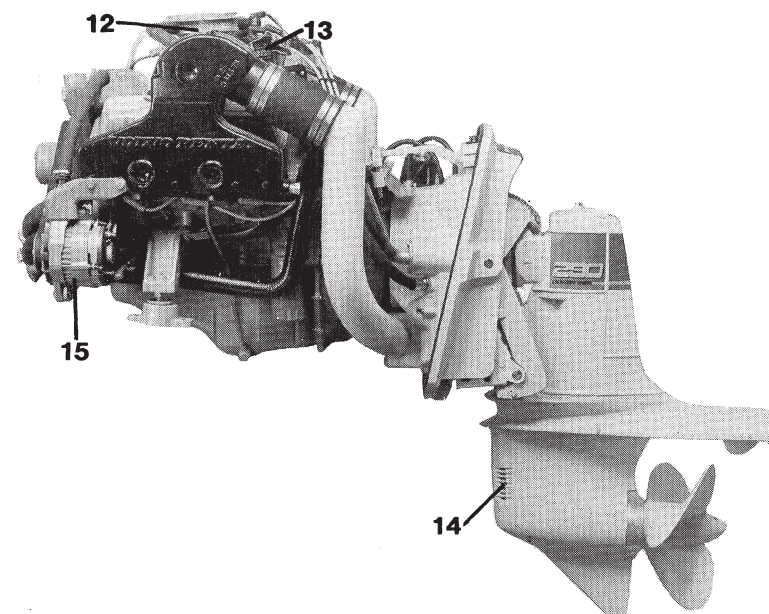

Explanations, see page 32.

FAULT TRACING SCHEME

TRACING FAULTS WITH INTERRUPTIONS IN OPERATION

The fault tracing scheme below includes only the more common causes of faulty operation. With the help of the instructions given in this book it is usually possible to remedy most of the faults listed below. When in doubt, always contact the nearest Volvo Penta workshop.

Follow the instructions in the servicing scheme – this assures the best running reliability.

Engine will not start	Engine stops	Engine does not attain top speed at full throttle	Engine runs unevenly or vibrates abnormally	Engine overheats	PROBABLE CAUSE	See
●					Master switch not turned on, flat battery, broken electric cables or main fuse burnt out.	page 6, 19
●	●				Fuel tank empty, fuel cock closed, fuel filter blocked.	page 17
●	●		●		Water or impurities in fuel.	page 17
●	●	●	●		Defective spark plugs.	page 14
●					Burnt ignition breaker points, moisture on distributor and spark plug cables.	page 15
	●		●		Idling speed not correctly adjusted.	page 16
		●			Defective revolution counter.	
		●			Boat abnormally loaded.	
		●			Marine growths and fouling on the boat bottom and outboard drive.	page 23
			●		Propeller damaged.	page 24
				●	Blocked cooling water intake, sea-water filter, defective pump impeller or thermostat	page 17

INDEX, ALPHABETICAL ORDER

Alternator.....	18	Launching	22, 23
Battery.....	19	Lubricating oil.....	4
Belt tension.....	15	Main switch.....	6
Charging regulator.....	18	Oil change.....	4, 13
Checks and service scheme.....	10	Oil dipstick, engine.....	11
Components guide.....	32, 33	Oil dipstick, outboard drive.....	11
Control.....	2	Oil level, Power Trim.....	11
Cooling system.....	17	Oil filter.....	14
De-inhibiting.....	22	Preparations before starting.....	5
Drain cocks.....	9	Running.....	7
Electrical system.....	29, 30	Safety equipment.....	5
Fault-tracing scheme.....	36	Sea-water pump.....	17
Fuel.....	4	Spare battery.....	18
Fuel filter.....	17	Starter motor.....	19
Fusebox.....	19	Starting.....	6
Impeller.....	17	Technical Data.....	27, 28
Inhibiting.....	20, 21	Wiring diagrams.....	29, 30
Instruments.....	2		

LOA = m (ft.). Beam = m (ft.). Draught = m (ft.).
 Displacement = Fuel tank cap. = l (Imp.gals. = US gals.).
 Water tank = l (Imp.gals. = US gals.). Battery cap., std. circuits = Ah. Battery cap., opt. equipment circuit = Ah.

The light bulbs have the following wattage:

Instruments: W. Cabin: W. Pentry: W. Toilet: W. Com-
 pass: W. Ports/Startboard lights: W. Stern lights: W. Mast-
 head lights: W. Searchlight: W. Cockpit: W.

SUPPLEMENT TO 'OWNERS MANUAL'

AQUAMATIC ENGINE MODELS

**AQ200F/290A, AQ271A/290A,
AQ311A/290A, AQ200F/290DP,
AQ225F/290DP and AQ271A/290DP**

This supplement is dealing with items, deviating from what has been described in the basic Manual.

GENERAL INFORMATION

Important information to be aware of for the proper function of your engine.

FUEL

Use gasoline with at least an octane number of 91 (RON). The engine can be run on low-leaded fuel. See under 'Technical Data'.

The use of unleaded or low-leaded gasoline is more common today. Unleaded and low-leaded gasoline with other additives demand a special attention.

Prior to filling up the tank the next time, we ask you to observe the following:

Only use gasoline with a sufficient high octane number (NB! Not unleaded)

High octane gasoline normally has been supplied with lead additives. When it comes to gasoline containing a low amount of lead additives or low-leaded gasoline, often alcohol is added in order to maintain the octane number on the correct level.

If an engine, which is intended for gasoline with a normal lead content, is run on unleaded or low-leaded gasoline, it is quite possible that this will result in an increased wear on valve and valve seats. Alcohol does not have the same lubricating properties as lead.

Alcohol and then above all methanol in gasoline accelerates the ageing of rubber and plastic materials. This might cause fuel leakages. Out of reasons of security, all parts made of rubber or plastics and being part of the fuel system must be inspected often and regularly. Examples of such parts are: Fuel pump diaphragms, valves, fuel hoses, gaskets and fuel tanks. Always replace parts which you suspect being affected.

Gasoline mixed with alcohol is binding more water compared to pure gasoline. This might be the cause of increased corrosion on metallic components in the fuel system. Check often and regularly.

LUBRICATING OIL

Only use lubricating oil of the quality SF (SE) in accordance with the API System. Regarding other lubricating oil requirements — see under 'Technical Data'.

SPEED RANGES — FULL THROTTLE

When selecting the propeller it is often difficult to find a propeller dimension, which under different load and weather conditions will procedure the recommended 'full throttle speed'.

On certain types of boats it could be an advantage to obtain a lower 'full throttle speed' compared to what has been recommended as being the maximum speed. The advantage could be lower fuel consumption, lower noise- and vibration levels or a higher propeller efficiency etc. Therefore we recommend a 'speed range full throttle'. The cruising speed should then be 300-500 rpm lower than the full throttle speed obtained.

Speed range, full throttle — AQ200F 4000—4400 rpm

Speed range, full throttle — AQ225F 4000—4400 rpm

Speed range, full throttle — AQ271A 4000—4600 rpm

Speed range, full throttle — AQ311A 4600—5200 rpm

Carburettor

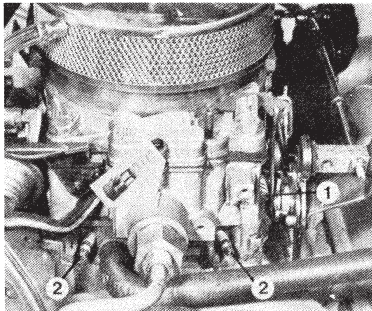

Air screw on a carburettor model 'Rochester'

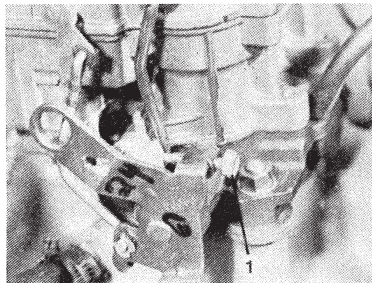

Engine speed screw

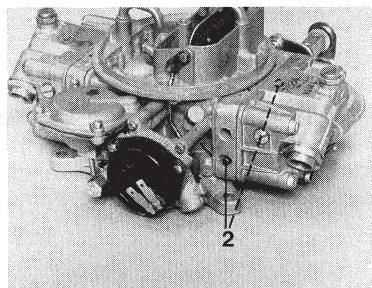

Air screws on a carburettor model HOLLEY. Also on opposite side!

CHECKS AND SERVICE

To obtain a properly running engine with optimum fuel economy, the correct carburettor setting is a 'must'. Therefore let your authorized service workshop check the carburettor setting some time during the season.

Adjust the idling setting as follows:

- 1 Run the engine warm until it has reached its operating temperature and with the choke fully open.
- 2 Set the idling speed (see under 'Technical Data') with the engine speed screw (1).
- 3 Check to make sure there is no air leakage between the carburettor and the inlet manifold — this would cause an increase of the engine speed.

Adjust the fuel-air mixture with the air screw (2) to obtain the best and smoothest idling. Start by tightening the air screw until the engine starts running roughly and back it off until the best idling has been obtained. Tune the speed with the engine speed screw if necessary.

Fuel filter by the carburettor

The carburettor is provided with a fuel filter located at the connection of the fuel line to the carburettor.

Check the filter at least once per season or when necessary

Checking: Ease off the fuel line and remove the nipple in the filter housing (watch out not to spill fuel!) It is now possible to remove the filter to check it. (Wash it in white spirit or its equivalent). Please observe the spring, inside the filter. Install in reversed order. The closed end of the filter should face the spring. Check the gasket between the nipple and the filter housing and replace it if necessary. Start the engine and make sure that all connection are tight.

FUEL FILTER BY THE FUEL PUMP

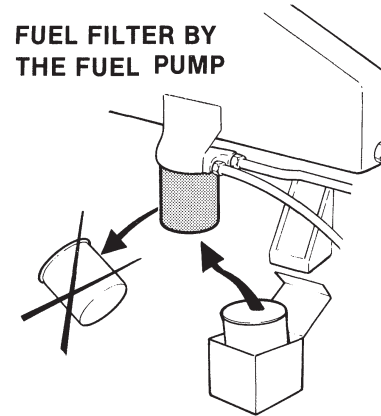

The fuel filter must be replaced once per season or after every 100 hours of operation. Remove the filter, discard it and install a new one. Watch out not to spill fuel!!

Fuses in the electrical system (Power Trim)

The electric system of the Powerim installation contains a 55 Amp fuse, installed by the starter motor and a 5 Amp fuse by the control.

INHIBITING

Replace the fuel filter.

PROPELLER — Sterndrive model 290

Selecting the propeller

The correct propeller has been selected when the 'speed range — full throttle' has been obtained and the with a fully loaded boat (normal load).

Select a left hand rotating propeller in a single installation. Thus the tendency of the boat to veer or run 'leaning over' is counteracted.

In a twin installation the port propeller should be left hand rotating and the starboard propeller right hand rotating.

When in need of replacing the propeller, make sure that you are getting a new, genuine Volvo Penta propeller with the same data as the old one. The size is stamped into the propeller hub. The dimension is given in inches — examples: 15x17 where 15 stands for the diameter and 17 for the pitch.

REMOVING AND INSTALLING THE PROPELLER

With the boat on land for winter storage, the propeller must be removed and the propeller shaft protected with a coating of anti-rust oil.

The propeller is locked with a propeller cone and a locking screw through its center. NOTE! Observe the plastic washer between the cone and the propeller. Pull off the propeller. Inside the propeller there is a spacer sleeve with a fishing line deflector.

Always replace a damaged propeller!

Prior to installing the propeller the propeller shaft must be greased. Use the Volvo Penta grease pad, p/n 828250-1. This in order to prevent the propeller from getting stuck onto the propeller shaft.

When installing the propeller, start with the spacer sleeve. Then the propeller and the plastic washer and finally the propeller cone. Tighten the propeller cone with its locking screw.

How to install a long-hub type of propeller:

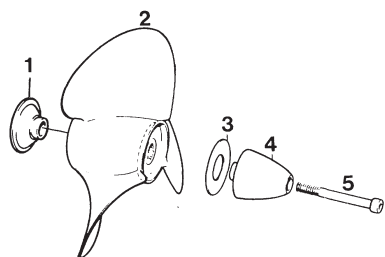

- 1 Coat the propeller shaft with a thin coat of grease.
- 2 Install the fishing line deflector (1)
- 3 Install the propeller (2)
- 4 Install the plastic washer (3)
- 5 Install and tighten the propeller cone (4)
- 6 Install and tighten the center screw (5).

PROPELLERS, sterndrive model DUOPROP

WARNING!

There are 2 different series of propellers for the sterndrive DUOROP. Series 'A' painted black is intended for use only on the diesel engines and a Series 'B', painted white, only on gasoline engines.

Series 'B' is allowed for use only on the V8 Aquamatics. The use of Series 'A' is prohibited while these propellers, installed and used together with the V8 Aquamatics, would render the boat unstable and with subsequent unexpected turns at high speed.

The front and rear propellers are matched. Propellers with different markings are not to be installed together. A damaged propeller must be replaced as quickly as possible. If you have to operate the boat with one propeller damaged, then do it carefully and with as low load as possible on the propellers. To run the boat with only one propeller is prohibited as this might damage the propeller shafts.

The front propeller (2) is locked with a nut (4) and a locking washer (3). One of the teeth of the locking washer should fold into one of the recesses of the locking nut. The rear propeller (6) is locked with the nut (7), key width 24 mm. The nut is locked with the screw (9), key width 13 mm. Grease the propeller shaft. Use the Volvo Penta grease pad, part number 828250-1!

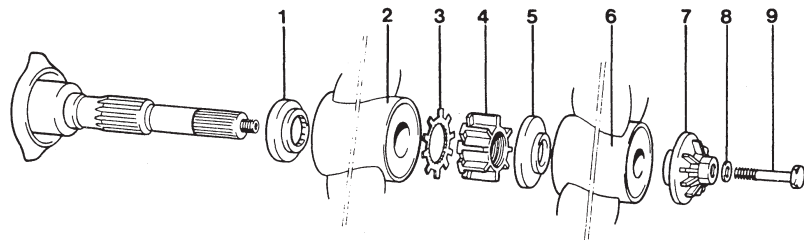

'TECHNICAL DATA'

General:

Engine designation.....	AQ200F	AQ271A
	AQ225F	AQ311A
Type.....	4-cycle	4-cycle
Number of cylinders (90°V).....	8	8
Output (see 'Sales Literature')		
Bore mm (in).....	95 (3.75)	101.6 (4.0)
Stroke mm (in).....	88.4 (3.48)	88.4 (3.48)
Swept volume dm ³ (cu. in).....	5 (305)	5.74 (350)
Compression ratio.....	8.5:1	8.5:1
Compression pressure (starter motor).....	10.0-11.0	10.0-11.0
	kp/cm ²	kp/cm ²
	(142-156 p.s.i)	(142-156 p.s.i)
Recommended 'cruising speed'.....	300-500 rpm lower than the obtained max. speed	
Idling speed.....	750 rpm	
Direction of rotation (seen from front of engine).....	Clockwise	
Maximum propeller diameter.....	16"	
Gross weight (engine, risers and sterndrive) kg (lbs)	400 (880)	
Ratio, sterndrive model 290A.....	1,61:1	1,61:1
sterndrive model 290DP.....	1,95:1	1,95:1*
* NOTE! Sterndrive model 290DP not available for AQ311A!		

Valves

Valve system..... Overhead valves Hydraulic lifters (non-adjustable)

Cooling system

Thermostat, limit values °C (°F)..... 62—72 (153—160)

Fuel System

AQ200F, AQ225F — Carburetors model..... 'Rochester'
 AQ271A, AQ311A — Carburetors model..... 'Holley'

Fuel Quality

Gasoline with an octane value of min. 91 (RON). The engines should be run on low-leaded fuel.

Lubricating System

Engine:		Service SF (SE)
Oil Quality.....	SAE	10W/30
Viscosity.....	4/4.2	
Capacity, excl oil filter, litres/US qts.....	AQ200F	
	5/5.3	
	AQ225F	
		5/5.3
Capacity, excl oil filter litres/US. qts.....	4.4/4.7	
Capacity, incl oil filter litres/US. qts.....	AQ200F	
	5.4/5.7	
	AQ225F	
Capacity incl. oil filter litres/US. qts.....		5.4/5.7
		AQ271A
Capacity incl. oil filter litres/US. qts.....		5.6/5.9
and oil cooler		AQ311A

Capacity between min and max marks on the dipstick litres/US. qts.....	1.0/1.0	1.0/1.0
Sterndrive, model AQ290A:		
Oil quality/viscosity.....	Same as engine	
Capacity litres/US. qts.....	2.6/2.7	
Capacity between min and max marks on the dipstick litres/US. qts.....	0.15	
Sterndrive, model 290DP		
Oil quality/viscosity.....	API-GL5 (SAE90 or 80W90)	
Capacity litres/US. qts.....	2.7/2.8	
Capacity, Power Trim hydraulic system litres/US. qts.....	0.52	
Quality, Power Trim hydraulic system.....	API-GL5 (SAE90 or 80W90)	

Ignition System

Firing order.....	1-8-4-3-6-5-7-2
Stroboscope setting.....	30°BTDC AQ271/311 = 28-30°BTDC 3000 rpm 8°BTDC
Basic setting.....	
Distributor, contact gap mm (in).....	0.36-0.48 (.014-.019")
Closing angle — AQ220F, AQ225F.....	28°—34°
Sparks Plugs --- Volvo Penta p/n 858816-1 gap mm (in)	0.7 (.028")

Electrical system

Voltage.....	12 V (negative ground)
Battery capacity.....	60 Ah
Battery electrolyte spec. gravity.....	1.275-1.185
to be recharged at.....	1.230
Alternator, max output Amp (W).....	50 (50x14)
Starter motor output kW (hp).....	0.96 (1.3)

Tightening torques

Cylinder head bolts.....	90 Nm 9.0 kpm 66 lb. ft
Spark plugs.....	21 Nm 2,1 kpm 16 lb. ft.
Steering helmet bolts (Aquamatic).....	35 Nm 3,5 kpm 26 lb. ft

WIRING DIAGRAM

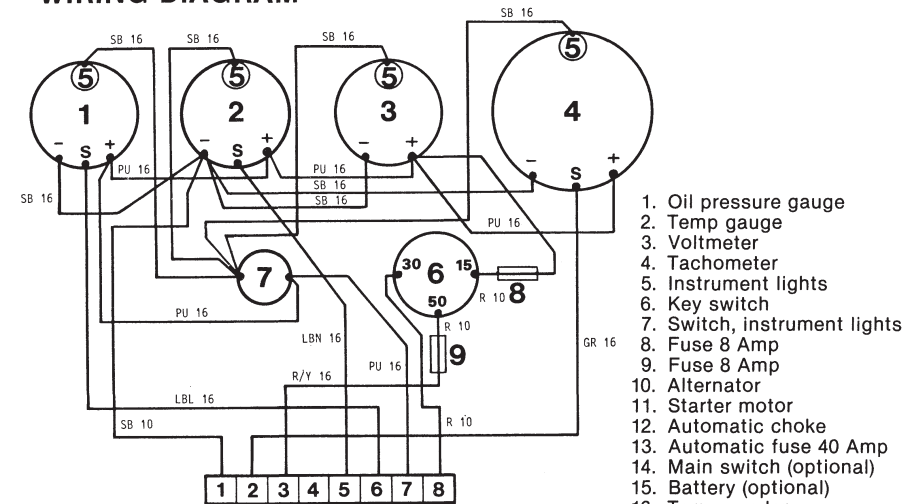

1. Oil pressure gauge
2. Temp gauge
3. Voltmeter
4. Tachometer
5. Instrument lights
6. Key switch
7. Switch, instrument lights
8. Fuse 8 Amp
9. Fuse 8 Amp
10. Alternator
11. Starter motor
12. Automatic choke
13. Automatic fuse 40 Amp
14. Main switch (optional)
15. Battery (optional)
16. Temp sender
17. Oil pressure sender
18. Distributor
19. Ignition coil
20. Relay
21. Resistor

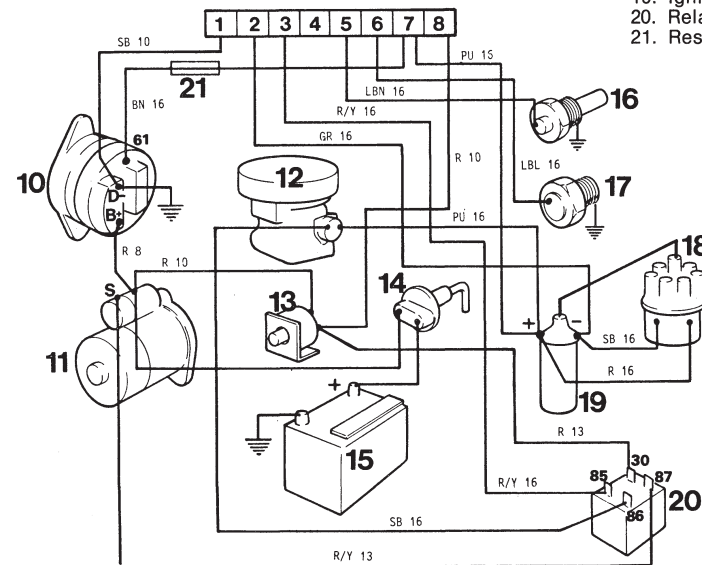

Color	GR	AWG	mm ²
SB = black	LBL = light blue	16	1.5
PU = purpur	R/Y = red/yellow	13	2.5
LBN = light brown	BN = brown	10	6.0
R = red	W = white	8	10.0

SUPPLEMENT TO 'OWNERS MANUAL'

AQUAMATIC ENGINE MODELS AQ225E/275 and AQ271B/275

This supplement is dealing with items, deviating from what has been described in the basic Manual.

GENERAL INFORMATION

Important information to be aware of for the proper function of your engine.

FUEL

Use gasoline with at least an octane number of 91 (RON). The engine can be run on low-leaded fuel. See under 'Technical Data'.

The use of unleaded or low-leaded gasoline is more common today. Unleaded and low-leaded gasoline with other additives demand a special attention. Prior to filling up the tank the next time, we ask you to observe the following:

Only use gasoline with a sufficient high octane number (NB! Not unleaded)

High octane gasoline normally has been supplied with lead additives. When it comes to gasoline containing a low amount of lead additives or low-leaded gasoline, often alcohol is added in order to maintain the octane number on the correct level.

If an engine, which is intended for gasoline with a normal lead content, is run on unleaded or low-leaded gasoline, it is quite possible that this will result in an increased wear on valve and valve seats. Alcohol does not have the same lubricating properties as lead.

Alcohol and then above all methanol in gasoline accelerates the ageing of rubber and plastic materials. This might cause fuel leakages. Out of reasons of security, all parts made of rubber or plastics and being part of the fuel system must be inspected often and regularly. Examples of such parts are: Fuel pump diaphragms, valves, fuel hoses, gaskets and fuel tanks. Always replace parts which you suspect being affected.

Gasoline mixed with alcohol is binding more water compared to pure gasoline. This might be the cause of increased corrosion on metallic components in the fuel system. Check often and regularly.

LUBRICATING OIL

Only use lubricating oil of the quality SF (SE) in accordance with the API System. Regarding other lubricating oil requirements — see under 'Technical Data'.

SPEED RANGES — FULL THROTTLE

When selecting the propeller it is often difficult to find a propeller dimension, which under different load and weather conditions will procedure the recommended 'full throttle speed'.

On certain types of boats it could be an advantage to obtain a lower 'full throttle speed' compared to what has been recommended as being the maximum speed. The advantage could be lower fuel consumption, lower noise- and vibration levels or a higher propeller efficiency etc. Therefore we recommend a 'speed range full throttle'. The cruising speed should then be 300-500 rpm lower than the full throttle speed obtained.

Speed range, full throttle — AQ225E/275 4000—4400 rpm

Speed range, full throttle — AQ271B/275 4000—4600 rpm

Carburettor

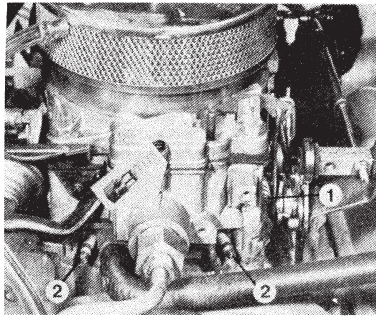

Air screw on a carburettor model 'Rochester'

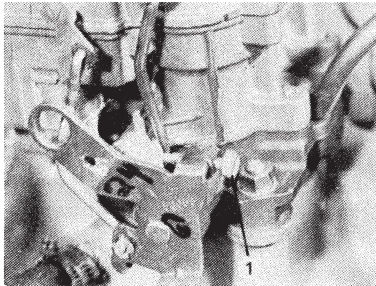

Engine speed screw

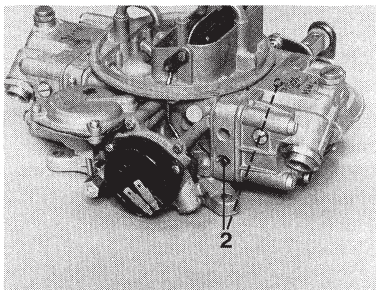

Air screws on a carburettor model HOLLEY. Also on opposite side!

CHECKS AND SERVICE

To obtain a properly running engine with optimum fuel economy, the correct carburettor setting is a 'must'. Therefore let your authorized service workshop check the carburettor setting some time during the season.

Adjust the idling setting as follows:

- 1 Run the engine warm until it has reached its operating temperature and with the choke fully open.
- 2 Set the idling speed (see under 'Technical Data') with the engine speed screw (1).
- 3 Check to make sure there is no air leakage between the carburettor and the inlet manifold — this would cause an increase of the engine speed.

Adjust the fuel-air mixture with the air screw (2) to obtain the best and smoothest idling. Start by tightening the air screw until the engine starts running roughly and back it off until the best idling has been obtained. Tune the speed with the engine speed screw if necessary.

Fuel filter by the carburettor

The carburettor is provided with a fuel filter located at the connection of the fuel line to the carburettor.

Check the filter at least once per season or when necessary

Checking: Ease off the fuel line and remove the nipple in the filter housing (watch out not to spill fuel!) It is now possible to remove the filter to check it. (Wash it in white spirit or its equivalent). Please observe the spring, inside the filter. Install in reversed order. The closed end of the filter should face the spring. Check the gasket between the nipple and the filter housing and replace it if necessary. Start the engine and make sure that all connection are tight.

FUEL FILTER

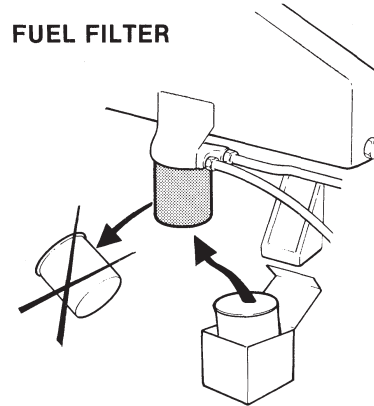

The fuel filter must be replaced once per season or after every 100 hours of operation. Remove the filter, discard it and install a new one. Watch out not to spill fuel!!

INHIBITING

Replace the fuel filter.

PROPELLER — Sterndrive model 275

Selecting the propeller

The correct propeller has been selected when the 'speed range — full throttle' has been obtained and the with a fully loaded boat (normal load).

Select a left hand rotating propeller in a single installation. Thus the tendency of the boat to veer or run 'leaning over' is counteracted.

In a twin installation the port propeller should be left hand rotating and the starboard propeller right hand rotating.

When in need of replacing the propeller, make sure that you are getting a new, genuine Volvo Penta propeller with the same data as the old one. The size is stamped into the propeller hub. The dimension is given in inches — examples: 15x17 where 15 stands for the diameter and 17 for the pitch.

REMOVING AND INSTALLING THE PROPELLER

With the boat on land for winter storage, the propeller must be removed and the propeller shaft protected with a coating of anti-rust oil.

The propeller is locked with a propeller cone and a locking screw through its center. NOTE! Observe the plastic washer between the cone and the propeller. Pull off the propeller. Inside the propeller there is a spacer sleeve with a fishing line deflector.

Always replace a damaged propeller!

Prior to installing the propeller the propeller shaft must be greased. Use the Volvo Penta grease pad, p/n 828250-1. This in order to prevent the propeller from getting stuck onto the propeller shaft.

When installing the propeller, start with the spacer sleeve. Then the propeller and the plastic washer and finally the propeller cone. Tighten the propeller cone with its locking screw.

How to install a long-hub type of propeller:

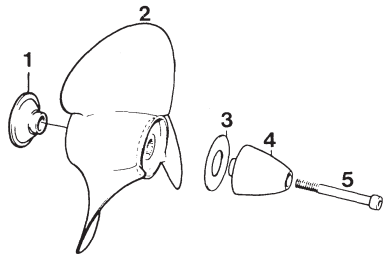

- 1 Coat the propeller shaft with a thin coat of grease.
- 2 Install the fishing line deflector (1)
- 3 Install the propeller (2)
- 4 Install the plastic washer (3)
- 5 Install and tighten the propeller cone (4)
- 6 Install and tighten the center screw (5).

'TECHNICAL DATA'

General:

Engine designation	AQ225E	AQ271B
Type:	4-cycle	4-cycle
Number of cylinders (90°V)	8	8
Output (see 'Sales Literature')		
Bore mm (in)	95 (3.75)	101.6 (4.0)
Stroke mm (in)	88.4 (3.48)	88.4 (3.48)
Swept volume dm ³ (cu in)	5 (305)	5.74 (350)
Compression ratio	8,5:1	8,5:1
Compression pressure (starter motor)	10.0-11.0 kp/cm ² (142-156 p.s.i.)	10.0-11.0 kp/cm ² (142-156 p.s.i.)
Recommended 'cruising speed'	300-500 rpm lower than the obtained max. speed	
Idling speed	750 rpm	
Direction of rotation (seen from front of engine)	Clockwise	
Maximum propeller diameter	16"	
Gross weight (engine, risers and sterndrive) kg (lbs)	400 (880)	
Ratio, sterndrive model 275	1,61:1	1,61:1

Valves

Valve system Overhead valves Hydraulic lifters (non-adjustable)

Cooling system

Thermostat, limit values °C (°F) 62—72 (153—160)

Fuel System

AQ225E — Carburettor model 'Rochester'
AQ271B — Carburettor model 'Holley'

Fuel Quality

Gasoline with an octane value of min. 91 (RON). The engines should be run on low-leaded fuel.

WIRING DIAGRAM

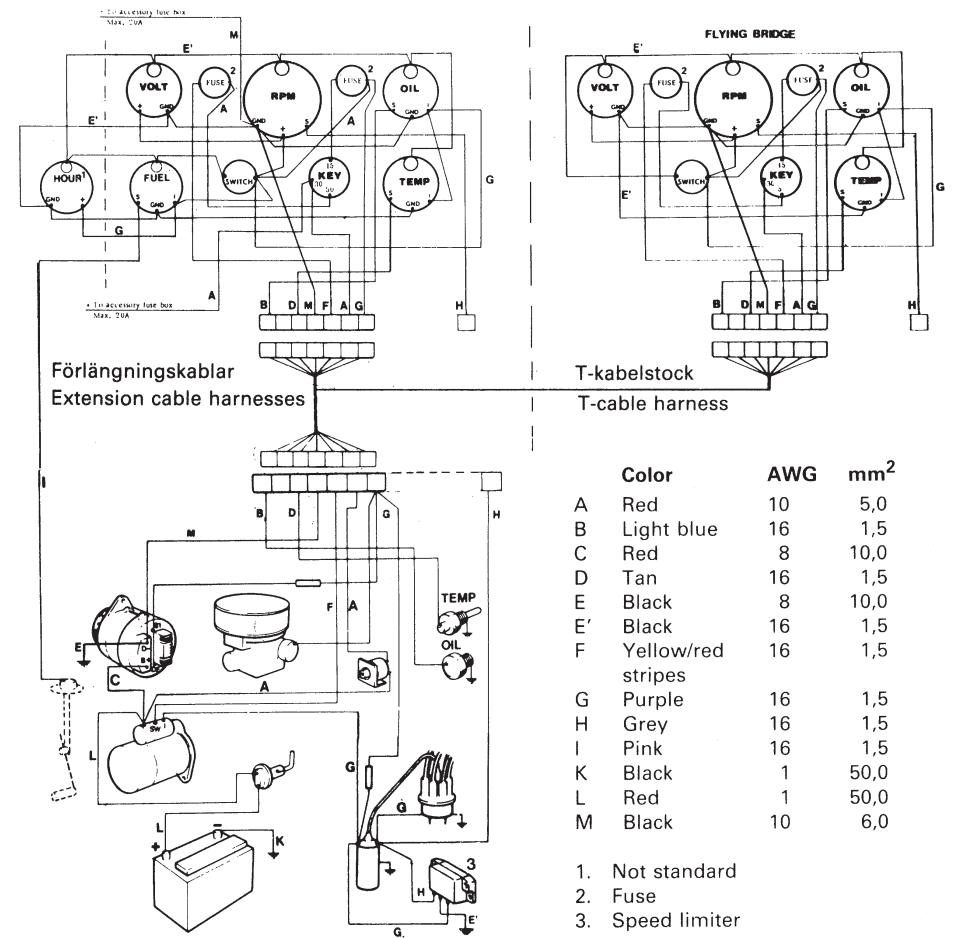

IMPORTANT INFORMATION

Warning!

Stop the engine before opening the hatch to the engine compartment. An engine which is in operation has rotating and moving parts which it is dangerous to touch.

Bear in mind the risk of a fire. All engine fuel is inflammable. Let an expert correct any faults in the fuel system and always use genuine Volvo Penta spare parts.

Frost Risk

The cooling system is filled with liquid and it should be drained when there is risk of frost. The fresh water part of the system can be filled with an anti-freeze mixture or drained. Note that in certain cases a suction action may occur when the sea-water system is being drained. Close all drainage points when the boat is not under constant supervision. Any incorrectly performed drainage can cause the boat to become filled with water and sink. Also bear in mind that the fresh water tank and the toilet can be damaged by frost.

To be Checked

The steering gear and controls must function perfectly and their operation should be checked at regular intervals. Never take any chances if you suspect that something is wrong. Take immediate action to remedy faults.

All rubber ages, so check all rubber parts at regular intervals. Parts which are of special importance are the fuel hoses and those rubber parts which have to do with the boat's flotation ability. If the hoses feel dry and hard or display any tendencies to crack they should be replaced immediately.

Safety Onboard

Check safety materials onboard. Run through in your mind what can happen and let yourself and your crew practice drills to cope with events that you know can happen. You will benefit by being prepared if anything does happen. If you take good care of your boat and its engine then the risk of anything happening is a small one. Read the instruction book – before it happens.

AB VOLVO PENTA
S-405 08 Gothenburg
Sweden

Personal Information

Name

Address

Phone

Nearest Volvo Penta Dealer

Name

Address

Phone

Technical Information

Engine type.....

Serial number, engine.....

Drive..... Ratio

Drive serial number, PZ

Propeller size

CHECKS AND SERVICE HAVE BEEN CARRIED OUT ACCORDING TO BELOW:

50 hour intervals

date ____ / ____ – by ____

date ____ / ____ – by ____

date ____ / ____ – by ____

date ____ / ____ – by ____

date ____ / ____ – by ____

100 hour intervals

date ____ / ____ – by ____

date ____ / ____ – by ____

200 hour intervals

date ____ / ____ – by ____

date ____ / ____ – by ____

