

VOLVO PENTA AQUAMATIC DUOPROP KAD32P/DP-S

4-cylinder, direct-injected marine diesel engine with charge air compressor, turbocharger, aftercooler and Duoprop drive. 125 kW (170 hp)*

* Crankshaft power according to ISO 8665

Compressor-charged Hi-Tech engine

Volvo Penta's 4-cylinder KAD32P is a compressor- and turbocharged high performance engine with aftercooler producing high torque at low engine speeds. This means unique acceleration properties and excellent drivability.

Reliable marine engine

KAD32P is a reliable and economic marine engine with considerable power resources and is specially developed for planing craft.

The engine is compact and has an advantageous weight to power ratio making it excellent for both single and multi-engine installation.

Direct injection

Direct injection (DI) results in a low thermal load and low fuel consumption compared with swirl chamber engines (IDI) with the same cylinder capacity.

Supercharging

The engine is supercharged with a mechanically driven compressor and an exhaust turbocharger. The compressor – fitted with silencers – supplies compressed air at low engine speeds and while accelerating. The turbo takes over when the charging pressure has reached the proper level.

The interaction of compressor and turbo produces high torque over the whole speed range and this contributes to cleaner exhaust gases and fuel economy giving excellent acceleration and driving characteristics.

Aftercooler

The air heats up and expands when it is compressed. In other words, it takes up more space. The aftercooler cools the compressed and heated air and raises its oxygen content so that the engine can use the fuel more efficiently.

Low exhaust emission levels

The direct injection, supercharging and aftercooler contribute to minimizing noxious exhaust emissions and enhancing overall enjoyment of boating.

Easy to service

The engine is designed for easy maintenance and service.

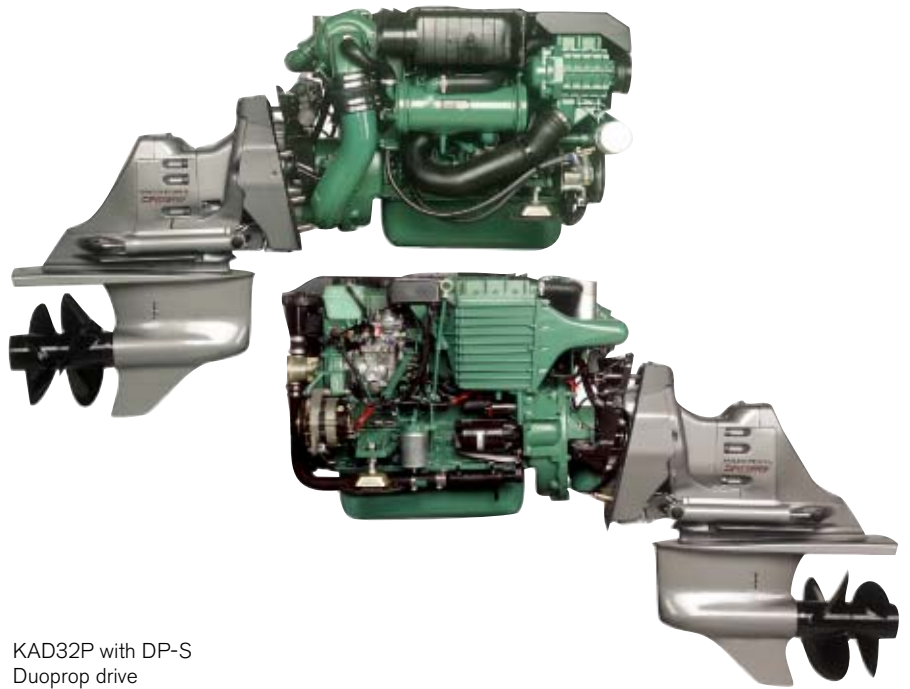

KAD32P with DP-S
Duoprop drive

All the important service points on the engine are conveniently located at the top and the port side.

Aquamatic

The Duoprop drive with its twin counter-rotating propellers and exhaust outlet through propeller hub and cavitation plate produces a harmonious drive unit with unbeatable characteristics in the boat in terms of speed, acceleration, steering, maneuvering, fuel economy and less noise and vibration.

The drive is equipped with cone clutch for easy and smooth shifting. Pattern-matched spiral bevel gears for optimum strength and minimum gear whine. Break-away shaft coupling to prevent costly drive train repairs. Sacrificial zincs located both on drive and transom shield.

The drive is equipped with easily maneuvered hydraulic power trim for obtaining the best running position at different sea and load conditions.

A choice of stainless steel and aluminum propellers available for different applications.

The KAD32P features standard power steering for maximum driving comfort.

Comprehensive service network

Volvo Penta has a well-established network of authorized service dealers in more than 100 countries throughout the world. These service centers offer Genuine Volvo Penta Parts as well as skilled personnel to ensure that you enjoy the best possible service.

Technical description:

Engine and block

- Cylinder block and cylinder head made of cast iron for good corrosion resistance and long service life
- Oil-cooled pistons with two compression rings and one oil scraper ring
- Replaceable wet cylinder liners
- Replaceable valve seats
- Five-bearing crankshaft

Engine mounting

- Two adjustable rubber mounts, one on each side of the engine, and two between transom shield assembly and engine

**VOLVO
PENTA**

KAD32P/DP-S

Lubrication system

- Pressure lubrication system with easily replaced full-flow oil filter on the side of the engine
- Tubular oil cooler that can be cleaned

Fuel system

- Rotor-type injection pump with a mechanical governor for accurate speed control
- Smoke limiter
- Fine filter with water separator
- Feed pump with hand primer
- Electrically operated stopping device

Air inlet and exhaust system

- Inlet system designed to produce optimal air rotation which provides perfect combustion. This results in high power and low fuel consumption.
- Air inlet silencer with replaceable filter
- Crankcase vent system with filter
- Air silencer on inlet and outlet side of compressor
- Seawater-cooled exhaust elbow of cast iron with a stainless steel insert
- Complete connection for exhaust outlet through the drive
- Exhaust-driven freshwater-cooled turbocharger
- Mechanically driven compressor

Cooling system

- Thermostatically regulated freshwater cooling
- Tubular heat exchanger with separate trans-

- parent expansion tank
- Coolant system prepared for hot water outlet
- Seawater strainer and easily accessible impeller pump

Electrical system

- 12V corrosion-protected electrical system, complete with instrumentation
- 14V/60A marine alternator
- Charging regulator with battery sensor for voltage drop compensation
- The alternator is prepared for a bulkhead-mounted double-diode set which automatically distributes the charge current to two separate battery circuits
- Automatic fuse with manual reset
- Starter motor power 3.0 kW
- Extension cable harness with plug-in connection available in various lengths

Instrument panel:

Separate instruments and harness or complete panel fitted with:

- Key switch
- Temperature gauge
- Instrument lighting
- Alarm for temperature, oil pressure and charging
- Voltmeter
- Rev counter
- Hour meter
- Oil pressure gauge
- Alarm test

Drive

- Duoprop

- Cone clutch
- Pattern-matched spiral bevel gears
- Exhaust outlet through propeller hub and cavitation plate
- Overload protection sleeve (break-away coupling)
- The drive can be tilted 55°
- The drive can be turned 28° in each direction with power steering
- Built-in kick-up function to reduce possible damage, in the event the drive strikes an underwater object
- Belt-driven power steering pump
- Oil cooler for power steering

Power Trim

- Electrically operated hydraulic system for trimming the drive for best driving comfort
- An analog instrument for indication of trim angle

Accessories

An extensive range of accessories for:

- Fuel system
- Control system
- Instruments
- Comfort & Safety
- Maintenance
- Cooling system
- Steering system
- Electric system
- Propeller & Drive

For detailed information, please see Accessory catalogs.

Technical Data

Engine designation	KAD32P
Crankshaft power, kW (hp)	125 (170)
Propeller shaft power, kW (hp).....	118 (161)
Engine speed, rpm.....	3800
Displacement, l (in ³)	2.4 (146)
Number of cylinders	4
Bore/stroke, mm (in.).....	92/90 (3.62/3.54)
Compression ratio	17.8:1
Volvo Penta Duoprop drive.....	DP-S
Ratio.....	1.95:1
Dry weight with DP incl. prop., kg (lb)	497 (1096)

Duty rating: R5

Technical data according to ISO 8665. Fuel with a lower calorific value of 42,700 kJ/kg and density of 840 g/liter at 15°C (60°F). Merchant fuel may differ from this specification which will influence engine power output and fuel consumption.

Contact your local Volvo Penta dealer for further information. Not all models, standard equipment and accessories are available in all countries. All specifications are subject to change without notice.a

The engine illustrated may not be entirely identical to production standard engines.

Dimensions KAD32P/DP-S

Not for installation

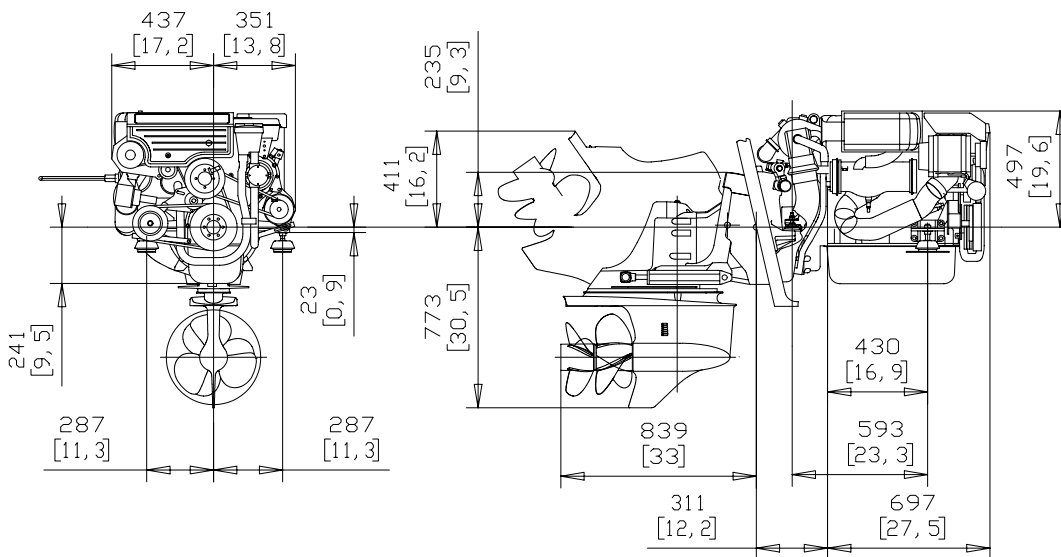

VOLVO PENTA

AB Volvo Penta
SE-405 08 Göteborg, Sweden
www.volvopenta.com