

# **INSTRUCTION BOOK**

**MD2010, 2020, 2030, 2040**

## Welcome on board!

You have chosen a boat with all the comfort you could ever wish for, plus an engine with maximum safety which will be extremely economical to run. We welcome you to our worldwide service network.

## Read this before you cast off from shore

We advise you to read through this Owner's Manual even if you are used to the sea and have previously piloted various types of boat. Some things may be different to what you are used to.

## Warranties and Service

Provided with each engine is a description of the warranty we issue for our product. The warranty card you receive should be filled in and returned to VOLVO PENTA by your sales representative: this is important both for us and for you. Make sure this is done, because we may refuse to undertake repairs on the warranty because the date of delivery cannot be verified.

Some markets have other warranty conditions which replace or supplement the VOLVO PENTA warranty.

## Diesel fuel

Use "Autodiesel" diesel oil. An inferior fuel may cause breakdowns.

## Lubricating oils

Only use lubricating oils of the quality recommended in "Technical Data".

## Maintenance

There are a number of maintenance instructions listed in this Owner's Manual. If these are not carried out in good time, your engine may become less reliable and less economical to run afterwards. Contact an authorised VOLVO PENTA service workshop if you are unable to carry out the prescribed maintenance yourself.

It is important that you always use original parts in order to maintain VOLVO PENTA quality. It will be worth it in the long run.

VOLVO PENTA has developed an extensive network of retailers in order to be able to provide services and spare parts.

**Always state the complete type designation and serial number when ordering spare parts**

## Safety instructions



When you see this symbol before an item of text, it means that there is a danger of injury or damage unless the instructions are followed.

## Maintenance Manual

This Owner's Manual contains brief operating instructions in the form of a maintenance schedule containing text and illustrations

For the "Do-It-Yourselfer" we have put together a more comprehensive Maintenance Manual which describes the engine and its fuel, lubricating and cooling systems, etc. in more detail. The Maintenance Manual also provides hints on the tools you will need.

The Maintenance Manual can be bought from your VOLVO PENTA retailer.

## Safety

### Preparations

We have put together the checklist below (to which you can, of course, add your own notes) in order that you may enjoy trouble-free running.

It is, of course, important that the engine, its equipment and the boat in general are maintained according to the instructions given in order to avoid breakdowns.

### Travel plans

- Do you have a current nautical chart for the planned voyage?
- Have you taken note of the weather forecast for the area in which you will be travelling?
- Have you calculated the distance?
- Have you calculated the amount of fuel you will need?
- Where can you buy fuel on your journey?
- Do your relatives know of your travel plans?

### The boat's equipment

- Rescue equipment such as lifejackets and distress rockets.  
Does everyone on board know where they are?
- Spare parts on board, e.g. water pump wheel (impeller) for the seawater pump.
- Tools which suit the equipment
- Full fire extinguishers.

## The environment

We invest large amounts of money in ensuring that our engines are as environmentally friendly as possible. We hope, therefore, that you as a boat owner will continue to help keep our environment clean.

As regards changes of oil and oil and/or fuel filters, it is important that used oil or discarded filters do not make their way into ordinary rubbish. Used filters always contain a small amount of oil or fuel even when they have been emptied.

**Always hand in used filters and oil to a service or environmental station which has special containers for products which can be harmful to the environment. Used batteries should also be handed in here.**

**AB VOLVO PENTA  
Technical Information**

# Instruction book

## Marine Diesel Engines

### MD2010, MD2020, MD2030, MD2040

#### Contents

##### Introduction

Engine description .....	2
Number plate and engine designation .....	3

##### Operation

Before starting .....	6
Starting .....	6
Stopping .....	7
Measures to be taken when freezing is imminent .....	7

##### Maintenance

Maintenance schedule .....	8
----------------------------	---

##### General information

Venting the fuel system .....	11
Coolant .....	11

##### Laying-up

Inhibiting .....	12
Recommissioning, launching .....	12

##### Electrical system

Electrical system .....	14
Wiring diagrams .....	15

##### Technical data

Engine .....	18
Reverse gear, S-drive .....	19

##### Troubleshooting

Troubleshooting schedule – engine .....	20
---	----

#### Important information

Standard instrument panels do not have a key switch. The operator's cabin should therefore be lockable and/or a lockable main switch should be used in order to prevent unauthorised persons from starting the engine.



Stop the engine before opening the door of the engine room! There are rotating parts on an engine which is running which are dangerous to approach. Bear in mind the risk of fire. All engine fuel is flammable.

The engine is fluid-cooled. Drain the seawater system after the engine has stopped if there is a risk of freezing. The freshwater system should be filled with an anticorrosion antifreeze solution.

Note that siphoning may occur when work has been carried out on the seawater system. Close all cocks if the boat is not supervised constantly. Drainage which has been carried out incorrectly may lead to the boat filling with water and sinking.

# Introduction

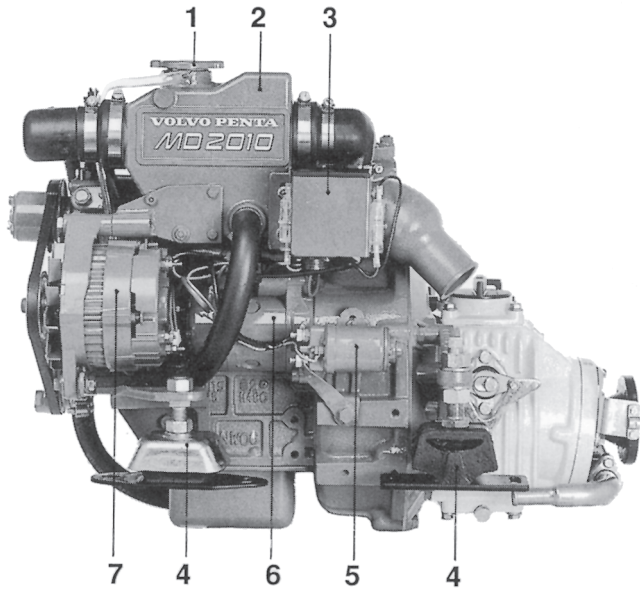

MD2010 with reverse gear MS2L-D

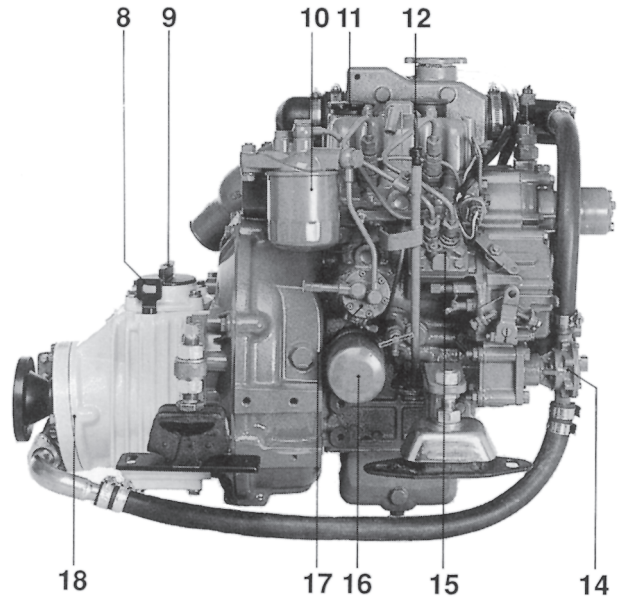

MD2010 with reverse gear MS2L-D

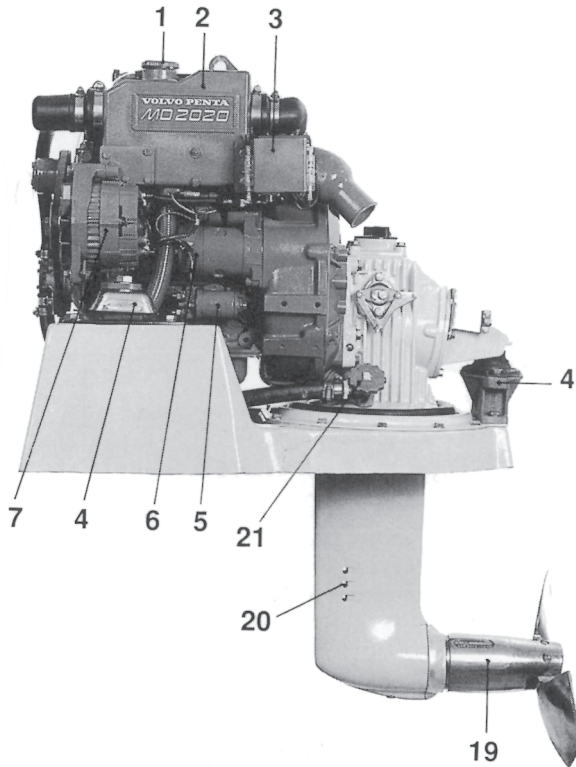

MD2020 with 120S-drive

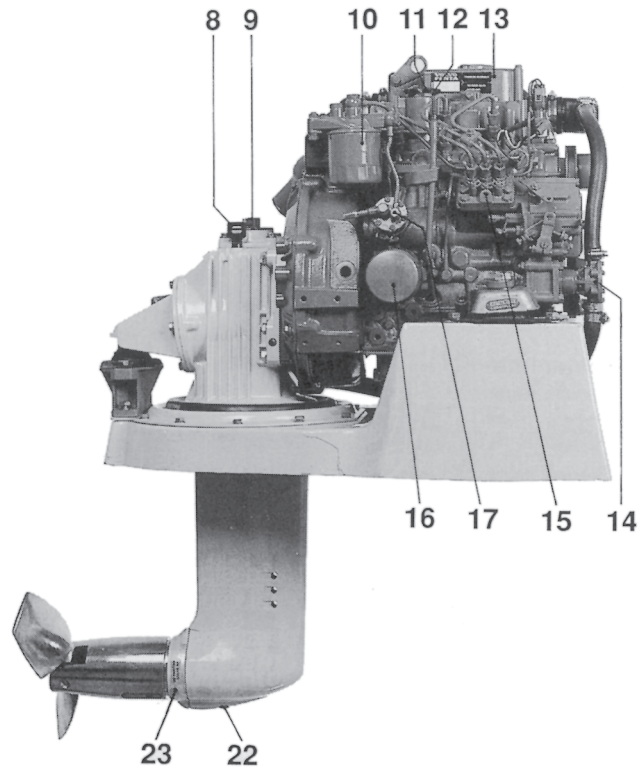

MD2020 with 120S-drive

## Illustrations for guidance (pages 2 and 3)

- |   |   |
|---|---|
| <ol style="list-style-type: none"> <li>1. Coolant filler cap</li> <li>2. Expansion tank</li> <li>3. Relay box with fuses</li> <li>4. Rubber mount</li> <li>5. Earthing relay (for starter motor and glow plugs)</li> <li>6. Starter motor</li> <li>7. Alternator</li> <li>8. Oil dipstick, reverse gear/S-drive</li> <li>9. Oil filler cap, reverse gear/S-drive</li> <li>10. Fuel fine filter</li> <li>11. Oil filler cap, engine</li> <li>12. Oil dipstick, engine</li> </ol> | <ol style="list-style-type: none"> <li>13. MD2040: Air filter. Other engines: Air intake</li> <li>14. Seawater pump</li> <li>15. Injection pump</li> <li>16. Lubricating oil filter</li> <li>17. Feed pump</li> <li>18. Oil cooler, reverse gear</li> <li>19. Folding propeller</li> <li>20. Cooling water intake, S-drive</li> <li>21. Bottom cock (seawater), S-drive</li> <li>22. Oil drainage, S-drive</li> <li>23. Zinc ring*</li> </ol> |
|---|---|

\* NB. A magnesium ring should be used when running in freshwater.

**Type designations (example)**

**Engine:**



Reverse gear designat.  
(or drive designation)  
 MS2A-D  
 Serial number  
 XXXXXXXXXX  
 Product number  
 873074



Approval No.  
(Certifying)

Engine designation  
 MD2040A  
 Serial number  
 868722  
 Product No.  
 51010XXXXXX

**Reverse gear/S-drive:**

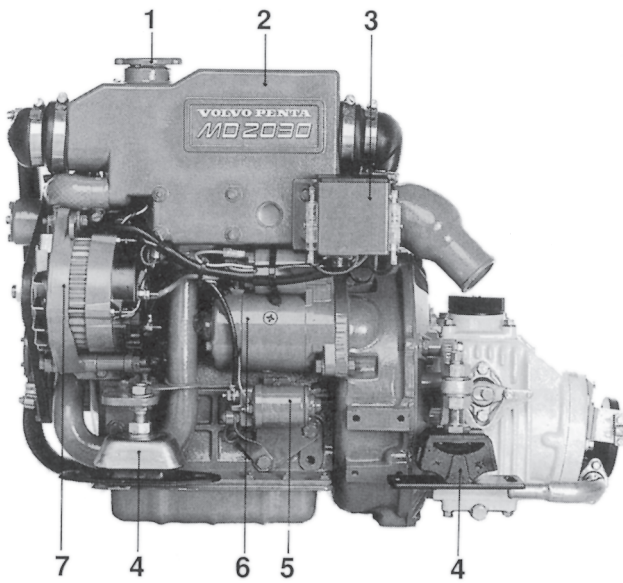
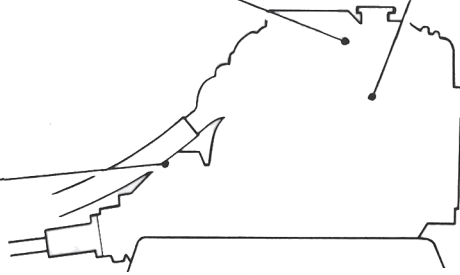
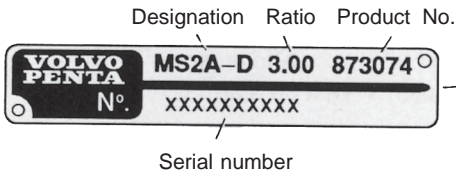

MD2030 with reverse gear MS2A-D

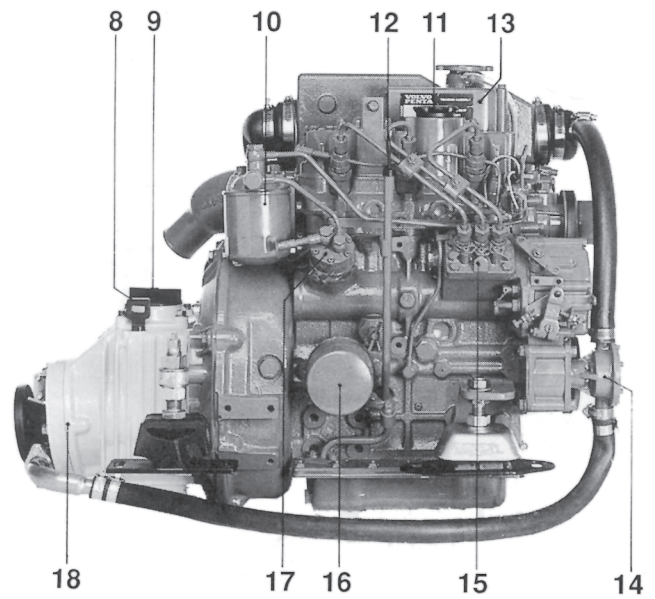

MD2030 with reverse gear MS2A-D

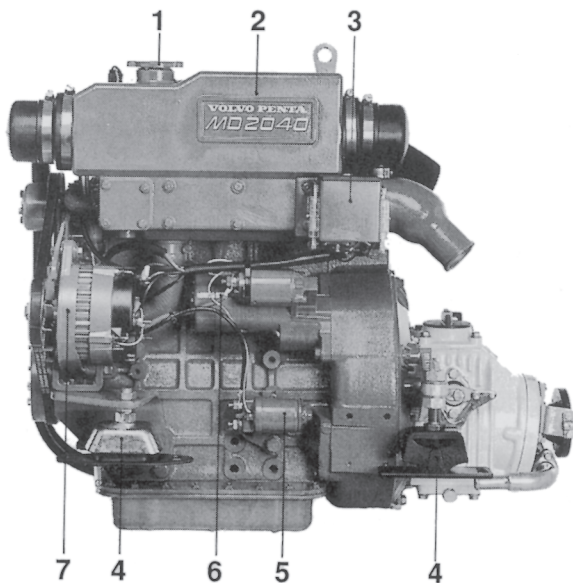

MD2040 with reverse gear MS2L-D

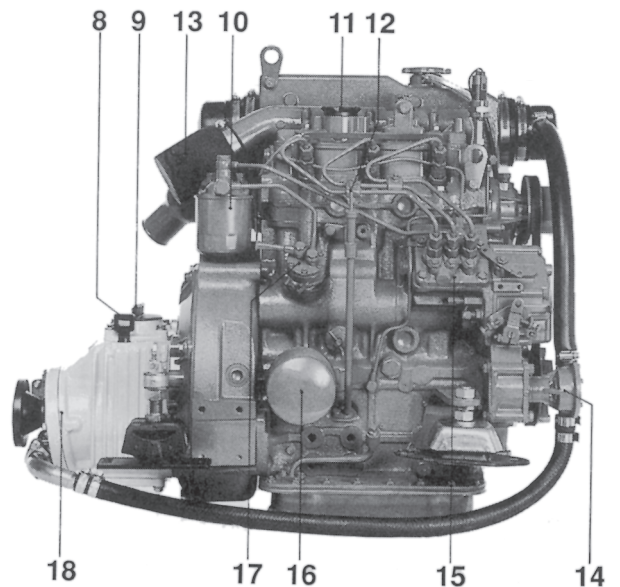

MD2040 with reverse gear MS2L-D

# Instruments

There are three types of main panel (A, B and C).

## Standard (alternatives "A" and "B")

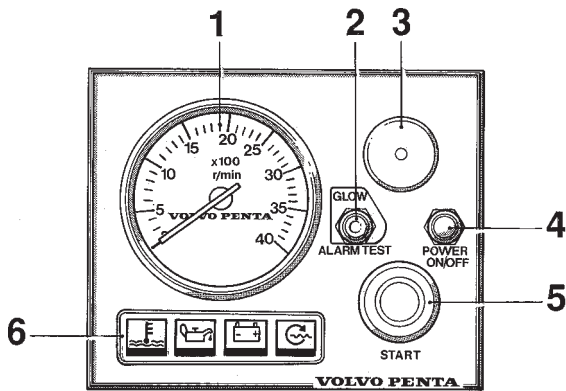

Instrument panel (standard),  
(with or without rev. counter)

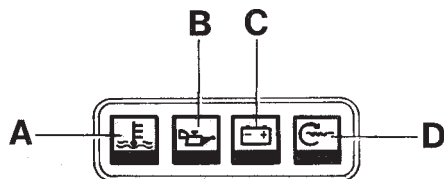

Warning display

## De luxe (alternative "C")

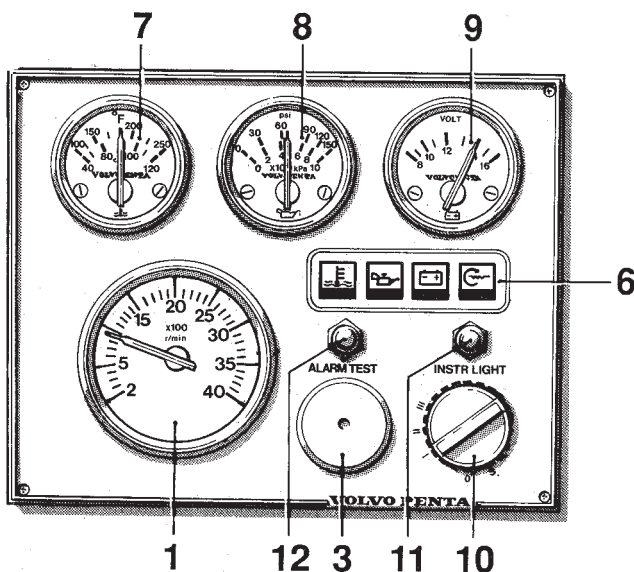

Instrument panel (De luxe)

### 1. Rev. counter/Blind plug\*

The rev. counter shows the engine speed. Multiply the value by 100 to calculate revolutions per minute. Full throttle: operating range: 3200–3600 r/min.

\* NB. Rev. counters come with instrument panels "A" and "C". Blind plugs come with instrument panel "B".

### 2. Toggle switch - Heating/Alarm test

Pos.: ↑ (up) = "Glow" position (glow plugs switched on).  
↓ (down) = Alarm test.

### 3. Alarm (siren)

### 4. Pressure switch for switching instrument panel On/Off (In/Out)

### 5. Start button

The starter motor comes on as soon as this button is pressed. Let the button go as soon as the engine has started.

See also the starting instructions on the next page.

### 6. Warning display

The display has four "windows". If the acoustic alarm comes on, one of windows "A–C" lights up (red) to show the cause of the alarm.

- A. **Coolant too hot.\*** Reduce the speed to idling (in neutral) until the temperature decreases. Investigate the cause of the alarm (**e.g. restricted water supply to the engine**). Stop the engine if the temperature does not decrease.
- B. **Lubricating oil pressure too low.** Stop the engine immediately and locate the cause of the alarm.
- C. **Alternator not charging.**
- D. **Heating (indicator lamp comes on when glow plugs are on).**

\* NB. The light will come on even if there is a problem with charging (no alarm sound).

### 7. Temperature gauge

The temperature gauge should normally show approx. 75–95°C (167–203°F) during normal operation. The acoustic alarm comes on when the coolant is too hot.

If an alarm is emitted, reduce the speed to idling (in neutral) until the temperature decreases. Investigate the cause (**e.g. restricted water supply to the engine**). Stop the engine if the temperature does not decrease.

### 8. Oil pressure gauge

The oil pressure gauge should normally show approx. 150–500 kPa (1.5–5 kp/cm<sup>2</sup> = 21–71 lbf/in<sup>2</sup>) during operation. It is normal for the gauge to show a lower value when the engine is idling.

The acoustic alarm comes on when the oil pressure is too low.

When the alarm sounds, stop the engine immediately and locate the cause.

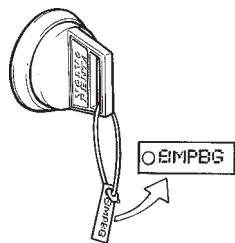
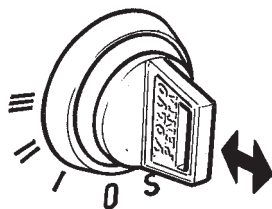

## 9. Voltmeter

The voltmeter shows the voltage in the starter battery circuit.

The voltage should be about 14V during operation. The voltage is about 12V when the engine is off.

## 10. Key switch

The key switch has five positions, including 0:

- Pos. **0** = Key can be inserted and removed.
- S** = The mechanical restart block disengages. The key springs back automatically to 0.
- I** = Running position. Key springs automatically back to running position after starting.
- II** = "Glow" position.
- III** = Start position (starter motor comes on). Let the key go as soon as the engine has started.

See also the starting instructions on the next page.

A disc is provided with the **keys** which gives the key code. This code must be stated when ordering new keys. Do not keep the number disc on the boat. Do not allow unauthorised persons access to the code.

## 11. Pressure switch – instrument lighting

## 12. Pressure switch – alarm test

## Controls

The Volvo Penta single-lever control combines the throttle and gear shift functions in one lever. When starting, for example, the gear change function can easily be switched off so only the engine speed is affected by the lever. When manoeuvring the boat backwards or forwards, the control mechanism makes the engine speed drop to idling speed when the gears are changed.

The control lever has an adjustable friction brake. A neutral position switch which allows the engine to be started only when reverse gear is not engaged is available as an extra.

### Manoeuvring takes place as follows:

Lever (1) for reverse gear/S-drive manoeuvres and engine speed control.

**Position N** = neutral position.

**From N to F** – reverse gear engaged for forward running.

**From N to R** – reverse gear engaged for reversing.

**T** = affects engine speed.

### Disengaging the reverse gear from the control:

Place the lever (1) in the neutral position "N". Press the button (2), push the lever forwards slightly and release the button. The lever will now only affect the speed.

The lever automatically reconnects the reversing function when it is moved back to the neutral position. The speed can then be adjusted and forward/reverse manoeuvres executed. **Ensure that the reverse gear/S-drive is not engaged unintentionally.**

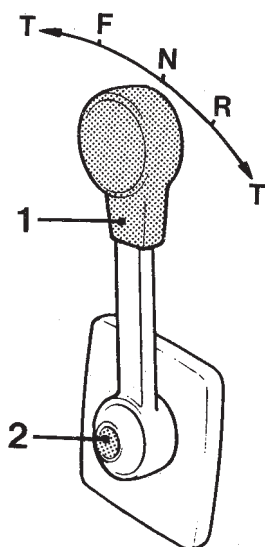

VP single control

# Operation

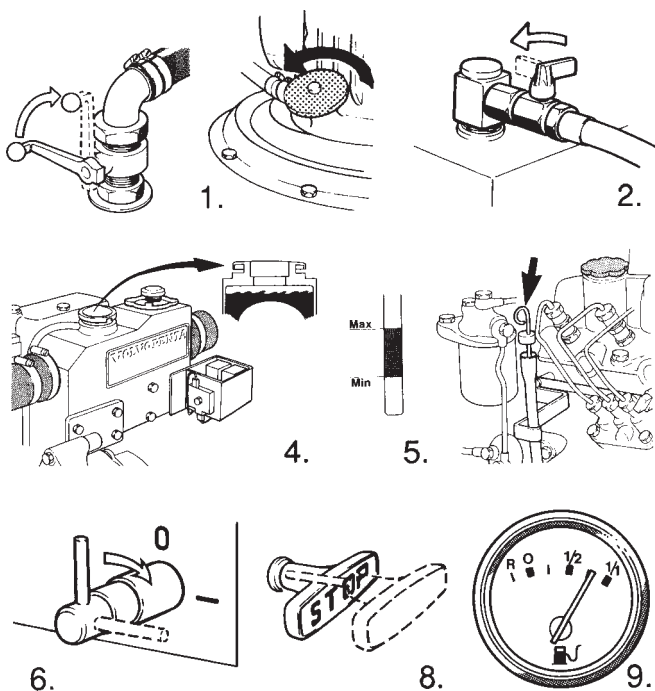

## Measures to be taken before starting

1. Open the bottom cock for the cooling water intake.
2. Open the fuel cocks.
3. Check that no leakage of water, fuel or oil occurs.
4. Check the level of coolant. The level should be just below the filler neck, or between the MIN and MAX marks on the separate expansion tank (extra).

**⚠ Open the cap carefully if the engine is hot.**

5. Check the engine oil level. This should be within the area marked on the dipstick.  
The oil level must never drop below the lower mark.
6. Engage the main switches.
7. Start the engine room blower (if fitted). Let it run for at least four minutes before starting the engine.
8. Push in the stop control.
9. Check the amount of fuel.

## Starting

**⚠ Warning!** Never use starting spray or similar products to help you start the engine. The glow plugs may cause an explosion in the inlet manifold. Risk of personal injury.

### Standard instrument panel ("A" or "B")

1. Disengage the control lever. Place the lever in the full speed position.
2. Press the "Power ON/OFF" switch (instrument panel comes on). Push the toggle switch down ("Alarm test") and check that the alarm sounds.
3. Push the toggle switch up to the "Glow" position and hold it there for about 20-30 sec. (max. 60 sec.).
4. Press the start button at the same time. Let the button and the toggle switch go when the engine starts.\* Reduce the engine speed to idle.

\*NB. Do not run the starter motor for more than 20 sec.

### De luxe instrument panel ("C")

1. Disengage the control lever. Place the lever in the full speed position.  
**NB.** Less throttle can be used when starting to reduce exhaust emissions.
2. Turn the key switch to position "I" (running position). The warning lights come on in this position. Press the "Alarm Test" button and check that the alarm sounds.
3. Turn the key switch to position "II" ("glow" position) and hold it there for about 20-30 sec. (max. 60 sec.).
4. Turn the key to position "III" to start. Release the key immediately once the engine has started\* (it will spring back automatically to the running position). Reduce the engine speed to idle.

\* NB. Do not run the starter motor for more than 20 sec. The key switch has a restart lock. Therefore, the starting procedure must always begin from the "S" position when repeated attempts are made to start the engine.

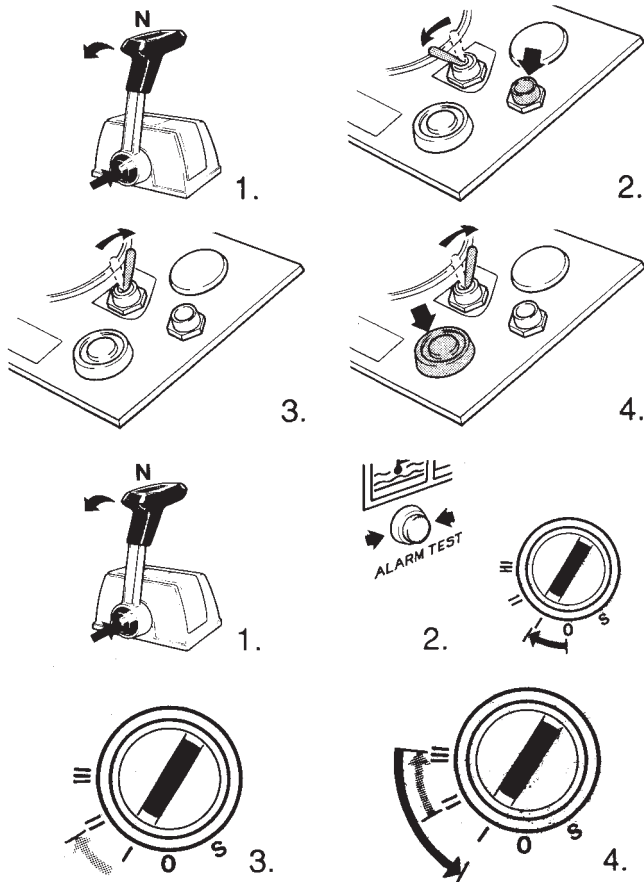
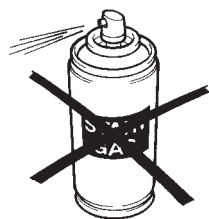



The following applies to all engines regardless of the type of instrument panel:

**⚠ NB:** The starter motor must **never** be switched on when the engine is running. The starter motor and the flywheel ring gear may be seriously damaged.

5. Warm up the engine at low speed and under low load. **Do not race the engine when it is cold.**
6. Monitor the instruments/warning display during operation. Stop the engine and check the cause of any abnormal readings or if a warning light comes on.

**The engine must not be run if the oil pressure is too low or the coolant temperature too high.**

**NB.** For maximum fuel economy, avoid running on full throttle. The maximum cruising speed is the maximum speed reached minus approx. 300 r/min.

When under sail, the control lever should be in the neutral position if the propeller is a fixed propeller. If the propeller is a folding propeller, the control lever should be in the reverse position. Start the engine and run for five minutes every ten hours when on long-distance cruises.

**⚠ Warning!** Manoeuvring of the reverse gear/S-drive should be done at idling speed. Manoeuvring at higher engine speed can damage the reverse gear/S-drive.

**NB:** Never switch off the power using the main switch when the engine is running. If you do, the voltage regulator and alternator may be seriously damaged.

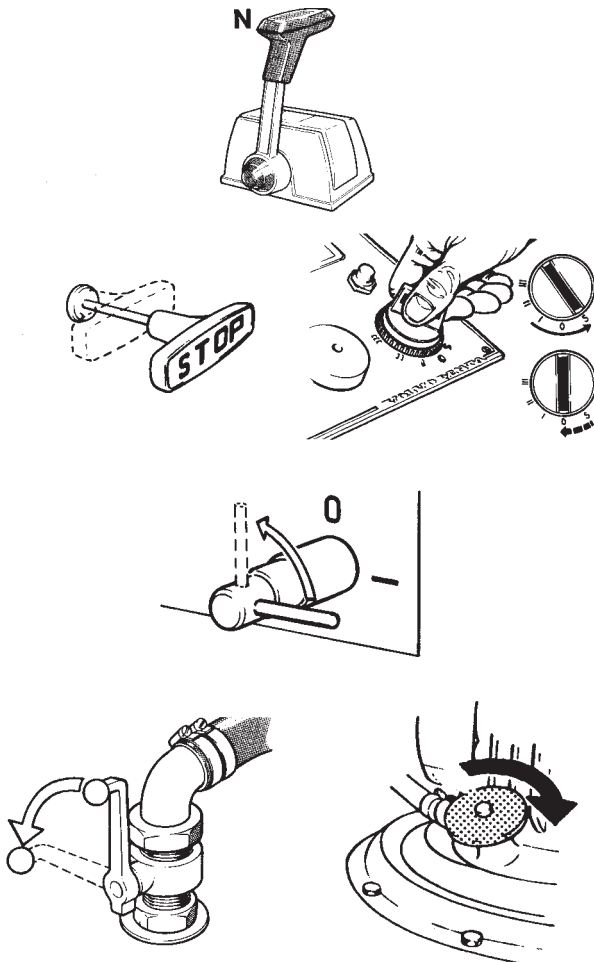

### Shutdown procedure

1. Let the engine run at idling speed for about 1 min after operation (with reverse gear/S-drive in the neutral position). This will ensure an equalisation of temperature in the engine and prevent “afterboiling”.
2. Pull out the stop control. Turn the key switch to the “S” position and release it (the key will automatically spring back into the “0” position). You may then remove the key.

### Safety measures:

3. Disconnect the main switches if the boat is not to be used for some time.
 

**⚠ NB:** Never disconnect the main switches when the engine is running. If you do, the voltage regulator and alternator may be seriously damaged.
4. Check there are no leaks around the engine and that everything in the engine room looks normal.
5. Close the sea cock (cooling water intake) and the fuel cocks.

**In cold weather, where there is a risk of freezing,** it is important that the coolant in the freshwater system has sufficient antifreeze.

Drain the water in the seawater system (see next section).

Check the battery’s charge. A battery with low charge can easily burst when frozen.

### Draining the seawater system:

**⚠ Do not allow the ingress of water into the boat.**

1. Close the bottom cock (sea cock). Release the cap on the seawater pump and let the water run out.
2. Release the hoses from the seawater pump and seawater filter at the reverse gear/S-drive and point them downwards so that the water runs out.
3. Tighten the hoses and the cap on the seawater pump.

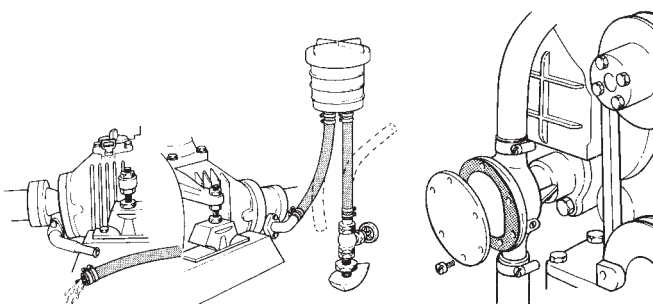

# Maintenance

General description for MD 2010, MD 2020, MD 2030 and MD2040.

 **NB: Stop the engine and cut the power using the main switches before service work is begun!**

## Check daily before starting

### 1. Check the coolant level.

 **Warning! Open the filler cap very carefully if the engine is hot. Steam or hot liquid may spray out.**

Turn the cap to the first stop and wait a moment before removing the cap.

The level should be just below the filler neck, or between the MIN and MAX marks on the separate expansion tank (extra). See the section entitled "Coolant" on page 11 for information on coolants.

A solution which is the same as that already in the cooling system should be used to replenish the system. **NB.** Fill the cooling system slowly!

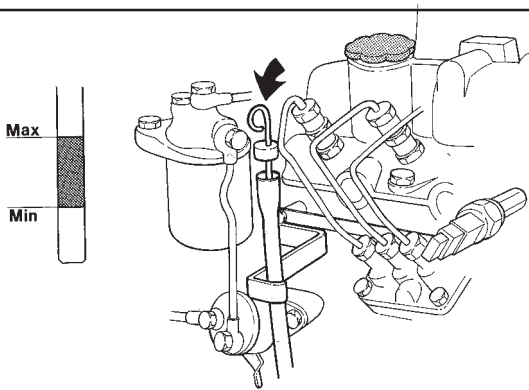
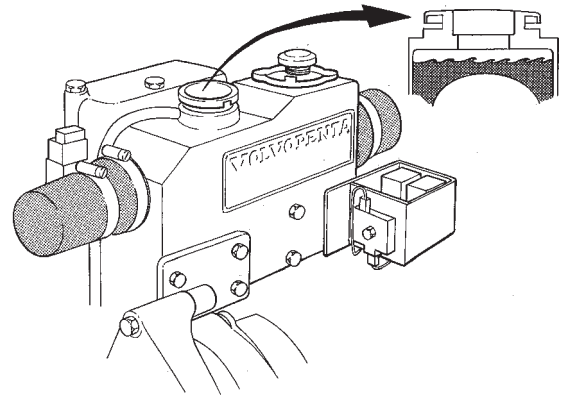

### 2. Check the engine's lubricating oil level.

The level should be within the area marked on the dipstick.

Add more oil if necessary. See "Technical data" regarding oil quality and viscosity. **NB. Fill the system slowly! The oil level must never fall below the lower mark.**

### 3. Check the oil level in the reverse gear or S-drive.

The level should be within the area marked on the dipstick. **NB.** The dipstick should **not be screwed in** when you check the oil level.

Add more oil if necessary. See "Technical data" regarding oil quality and viscosity.

**The oil level must never fall below the lower mark.**

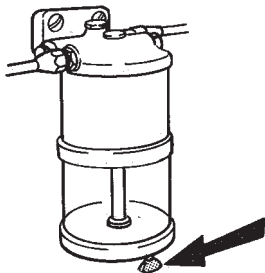
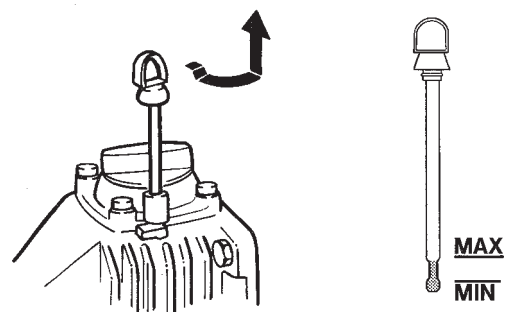

### 4. Drain water and any other impurities from the extra fuel filter (if applicable).

Drain water or impurities through the cock/plug (1).

**NB.** Wait a few hours after the engine has stopped before you drain the filter.

### 5. Check/tension the drive belt.

If the belt is too tight, it may damage the bearings. If the belt is too loose, it may make the belt pulley slip.

Change the belt if it looks worn or is cracked.

**After changing the belt:** Re-check the tension of the belt after about one hour's running.

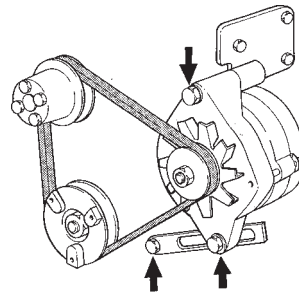
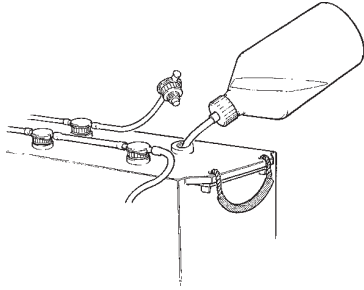

MD2010, MD2020

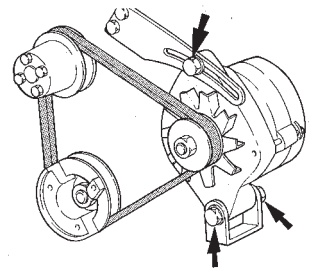

MD2030, MD2040

### 6. Check the level of electrolyte in the battery.

**Warning!** Use protective goggles. The batteries contain oxyhydrogen gas and extremely corrosive sulphuric acid. A spark or naked flame in the vicinity of the battery can cause an explosion.

## Service every 50 hours of operation

### 7. Check the seawater filter.\*

Close the sea valve. Open the filter, clean it if necessary.

**Warning!** Take care not to let in water.

\* NB. When to check the seawater filter should be determined from experience after running the boat for a time. Check the filter more often should there be a danger that it will get blocked.



## Service every 100 hours of operation, or at least once every 6 months

### 8. Change the engine oil.\*

See "Technical data" regarding oil quality and viscosity.

**Warning!** Hot oil can cause burn injuries.

**NB. Fill up slowly! Check that you are using the correct amount.**

\* NB: The oil should be changed after the first 20–40 operating hours in a new or reconditioned engine.

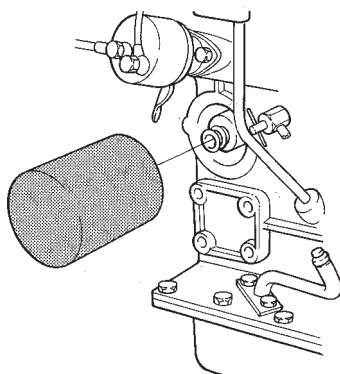
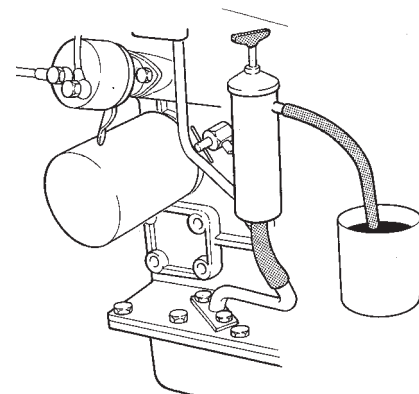

### 9. Change the lubricating oil filter.\*

Screw on the new filter by hand until the gasket is in close contact. Then tighten it by another 1/2 turn. Check for leaks.

\* NB: The oil filter should be changed after the first 20–40 operating hours for a new or reconditioned engine.

## Service every 200 hours of operation, or at least once a year

### 10. Drain the oil from the S-drive.

Use a collecting vessel. Contact an authorised Volvo Penta Service Workshop if the oil looks grey.

 **Warning! Hot oil can cause burn injuries.**

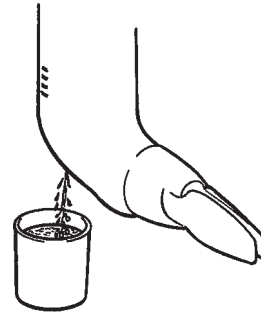
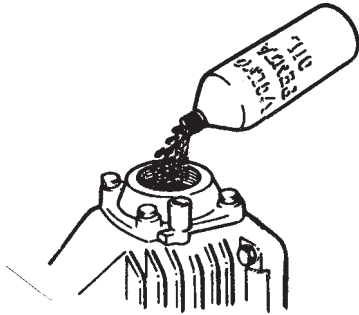

### 11. Refill the S-drive with new oil.

See "Technical data" regarding oil quality and viscosity.

**NB. Do not screw down** the dipstick when measuring the oil level. If there is too much oil, the excess must be drained off.

Check the tightening of the dipstick and the plug.

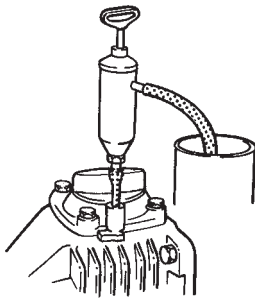

### 12. Change the oil in the reverse gear.

 **Warning! Hot oil can cause burn injuries.**

See "Technical data" regarding oil quality and viscosity.

Check the level. Top up with oil if necessary.

### 13. Change the fuel fine filter.

Be careful not to spill fuel! Screw on the new filter by hand until the gasket is in close contact. Then tighten it by another 1/2 turn.

Vent the system. See Item 15. Check the tightness.

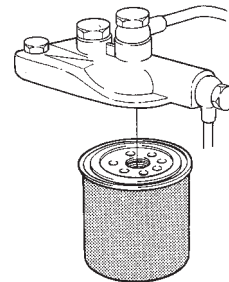

### 14. Change the insert in any extra fuel filter fitted.

Close the fuel cocks at the tank. Be careful not to spill fuel!

Clean the filter bowl. Fit a new filter insert and tighten it. Open the fuel cocks and vent the filter.

Check for leakage.

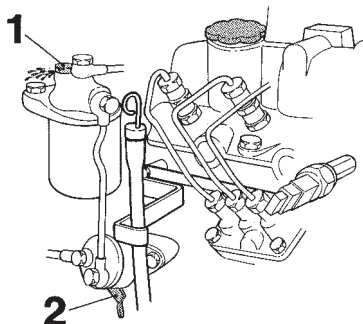
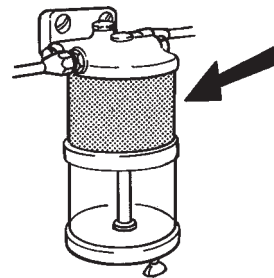

### 15. Vent the fuel system.

Open the venting screw (1) and pump using the hand pump (2) until fuel comes out which does not contain air bubbles. Close the screw while the fuel is flowing out. Avoid spilling fuel.

**NB.** Rotate the engine slightly if the pump output is poor.

---

## Service every 400 hours of operation, or at least once every other year

---

### 16. Clean the air filter (MD2040).

Remove the filter.

Carefully blow the filter clean using compressed air.

**NB. Impurities must not be allowed to enter the engine.**

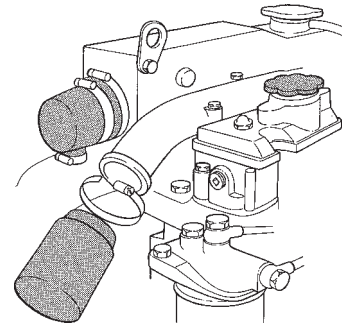

MD2040

---

## Other maintenance

Some checks are best carried out in connection with inhibiting/recommissioning. These maintenance actions are marked “–”.

**Some checks and maintenance actions require specialist knowledge, which is why we recommend that you consult an authorised service workshop. The following are of this type (marked “•”):**

**every 200 hours, or at least once a year:**

- Check/adjust idling speed.
- General check of the engine and its equipment.
  - Check the impeller in the seawater pump.\*
  - Check the S-drive’s zinc anode (zinc ring).\*
- Take apart and clean the vacuum valve, if fitted.\*
  - Lubricate the rubber propeller shaft seal (inboard engine).\*

**every 400 hours, or at least once every other year:**

- Re-tighten the cylinder head bolts.
- Check the valve clearance.
- Check the injectors.
  - Clean the cooling system and change the coolant.\*
  - Check that the heat exchanger is not blocked. If necessary, flush and clean it using suitable brushes.\*

\* NB. See the instructions under “Inhibiting” on the next page.

## Fuel system

Venting the fuel system

The fuel system must be vented in the following cases in order for the engine to start:

- After the fuel filter has been changed.
- After filling the tank with fuel if it has been run completely dry.
- After the fuel lines have been undone.
- After the boat has not been used for a long time.

**NB.** Refer to Item 15 in the maintenance schedule for venting.

## Cooling system

### Coolant

Use a mixture of 50% Volvo Penta antifreeze (glycol) and 50% clean water (as neutral as possible) for the engine’s internal cooling system (freshwater system).

**This mixture protects against freezing down to a temperature of approx. -40°C (-40°F) and should be used all year round.**

**NB.** At least 40% antifreeze should be used in the system in order to attain satisfactory anti-corrosion protection.

**⚠ NB: Glycol is harmful to health (dangerous to consume).**

**Topping up** shall use the same mixture as is already in the system. Topping up using only water will adversely affect the coolant’s properties as regards anti-corrosion protection, antifreeze and boiling point.

**NB.** Fill slowly! Check that the correct amount is being used.

**The cooling system** normally operates at a temperature of 75–95°C (167–203°F).

Too high coolant temperature (warning light comes on) may be caused by:

- A blocked seawater intake or seawater filter (optional).
- A defective seawater pump impeller.
- Low coolant level, air in the freshwater system.
- Slipping or broken circulation pump drive belt.
- Faulty thermostat, temperature sender or instrumentation.

**Be careful not to allow the ingress of water** when working with the cooling system.

**⚠ Ensure that water is not able to leak in and sink the boat if it has to be left with the cooling system dismantled.**

---

**Maintain quality and safety.  
Always use original VOLVO PENTA parts.**

---

# Inhibiting, Recommissioning

## Inhibiting an engine to be out of operation

The engine must be started and warmed up at least once every 14th day while the boat is in the water in order to prevent corrosion.

Check/top up the antifreeze in the freshwater system.

Should the boat not be used for more than 90 days, it should be put into long-term inhibiting as follows:

**NB.** Let an authorised service workshop test the engine and equipment before the boat is taken out of the water. Repairs can then be carried out while the boat is not being used.

Do the following while the boat is in the water:

1. Warm up the engine. Then stop it and drain or pump off the lubricating oil from the engine and reverse gear, if any.
2. Change the lubricating oil filter.
3. Fill Volvo Penta lubricating oil\* to the right level in the engine.
4. Fill lubricating oil\* to the right level in the reverse gear.

\*NB. See "Technical data" regarding oil quality and viscosity.

Do the following while the boat is on land:  
**Freshwater system**

Check/top up the antifreeze in the freshwater system.

**NB.** The coolant should be changed at least once every two years.

Unscrew the filler cap and open the drain cock. Flush through the drainage opening until clean water comes out. See under "Coolant" on page 11 regarding coolant.

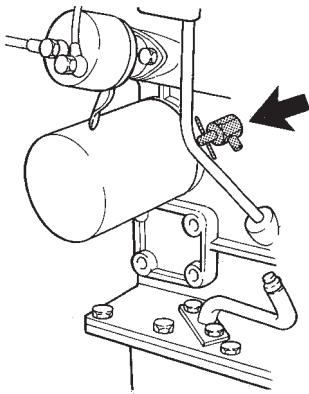

Location of drain cock (freshwater system)

## Seawater system

Release the hose at the seawater pump intake. Connect a hose to the pump and place the free end into a container of freshwater. Check that nothing is in danger of being splashed behind the exhaust discharge. Fill up the reservoir and start the engine. Let it run at a fast idle speed for a few minutes in neutral.

**! NB! The seawater pump should not be run dry (the impeller will be damaged).**

Fill the reservoir with a mixture of 50% Volvo Penta glycol and 50% freshwater, then repeat the same procedure.

Alternatively, a mixture of freshwater and emulsifying oil can be used. However, this mixture has no anti-freezing properties and must therefore be drained immediately after stopping.

**Hand the mixture in at a recycling plant. Never pollute the water.** Or drain the mixture and keep it to use again the next year.

**Remove the alternator/circulation pump drive belt.**

**Remove the seawater pump impeller.** Rinse the impeller in freshwater and keep it in a sealed plastic bag during laying-up if it is in good condition. (Otherwise fit a new impeller when launching the boat.)

Clean the outside of the engine and reverse gear/S-drive. Where necessary, touch up with original paint to avoid corrosion.

**! Warning!** Never direct the water at the propeller shaft seal when cleaning the S-drive with high-pressure jets.

**Remove the propeller** for winter storage and lubricate the propeller shaft with anti-corrosion oil.

**Protect control parts, cables and electrical system components against corrosion** using moisture-repellent spray.

**Remove the batteries from the boat.** Clean them and store them in a cool, dry place. Check that the batteries are well charged. Trickle charge them according to the manufacturer's instructions (a flat battery can easily be damaged as a result of freezing).

**Drain any water or impurities** in the fuel tank. **Fill the tank** to prevent the formation of condensation.

**Boat with S-drive:**

**Change the oil in the drive.** See Items 10 and 11 in the maintenance schedule.

Carefully check the rubber seal between the S-drive and the bed plate.

**! NB. The seal should be changed every 7 years.** This should be done by an authorised service workshop.

**S-drive with folding propeller:** Remove the folding propeller for winter storage.

Remove the blades' mounting pin locking screws. Knock out the pins and remove the blades. Remove the propeller shaft nut and pull off the propeller hub. Clean and lubricate the propeller shaft with anti-corrosion oil.

## Recommissioning – Launching

**Check the oil level** in the engine and reverse gear or S-drive.

**Change the engine fuel filter** and any extra fuel pre-filter. **Vent the fuel system.** See Items 13–15 in the maintenance schedule.

# Recommissioning, Launching

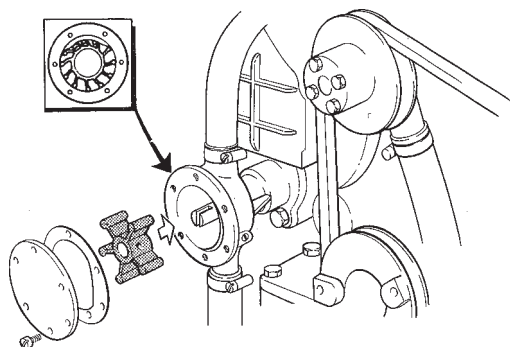

Fitting the impeller in the seawater pump

**Fit the impeller to the seawater pump.** Check that the impeller is in good condition. Change it if necessary. Lubricate the pump housing and the inside of the cover with a little lubricating grease. Press in the wheel while turning it (clockwise). Fit the grommet in the outer edge of the centre of the impeller. Fit the cover using a new gasket.

**Fit the alternator/circulation pump drive belt.** Change the belt if it is worn. See Item 5 in the maintenance schedule.

**Check the condition of the rubber hoses and the tightening of all hose clamps.**

**Take apart the vacuum valve** (where appropriate) for cleaning.

**Fit the propeller.** See the next section regarding fitting the propeller to the S-drive.

**Check the batteries' charge.** Connect the batteries.

**Boat with inboard engine fitted with a propeller shaft seal of rubber:**

Vent the tubular sleeve and seal after launching by pressing them together and pressing the seal down against the shaft until water emerges. Then press approx. 1 cm<sup>3</sup> of waterproof grease into the seal.

**Warning!** The propeller shaft seal must be changed after 5 years or a maximum of 500 operating hours.

## Fitting a propeller to the S-drive

**Warning!** Remove the key from the instrument panel or cut the power using the main switches before starting work on the propeller.

**Check the zinc anode\*** (zinc ring "4"). Change the anode if it is consumed more than 50%.

Otherwise clean the anode with an emery cloth to remove the oxide layer. **NB.** This should be done shortly before launching.

**NB:** Do not use a wire brush or other steel tools when cleaning, as these may damage the galvanic protection. Check that there is good metallic contact between the anode and the material.

\* NB: A magnesium anode should be used when running in freshwater.

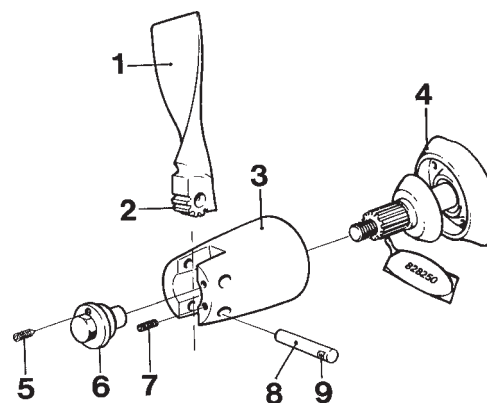

Fitting folding propeller to S-drive

- |                    |                  |
|--------------------|------------------|
| 1. Propeller blade | 6. Locking nut   |
| 2. Teeth           | 7. Locking screw |
| 3. Propeller hub   | 8. Pin           |
| 4. Zinc anode*     | 9. Grooves       |
| 5. Locking screw   |                  |

\* **NB:** A magnesium anode should be used when running in freshwater.

1. Put the control in the "Forward" position.
2. Carefully clean the propeller shaft and propeller hub (3).
3. Lubricate the shaft pivot and hub (grease pad 828250-1).
4. Fit the propeller hub to the shaft. Tighten the locking nut (6) by 65-75 Nm (6.5-7.5 kpm = 47-54 lbf. ft). Socket spanner 24 mm.
5. Fit the locking screw (5) and tighten it using a hexagonal key (4 mm).
6. Grease the pins (8) and the teeth (2) of the propeller blades.
7. Fit a propeller blade in the propeller hub and push the pin into a position such that the groove (9) in the pin end up right in the centre of the locking screw hole (7). Tighten the locking screw using a hexagonal key (4 mm).
8. Fit the other blade in the same way. Check that the blades form the same angle to the propeller shaft and that they move freely.

## Painting

Check the painting of the S-drive. Touch up damaged areas using Genuine Volvo Penta drive Paint. Then coat the drive with a Teflon®\* agent for aluminium drives. We recommend the Volvo Penta Anti-fouling Agents (part No. 1141593-2 or 1141594-0). These products are specially designed for the S-drive and are at the same time as kind to the environment as possible.

Paint the bottom of the boat and the propeller using a suitable anti-fouling paint or with a pure Teflon agent.

\* NB. Teflon is a registered trademark of Du Pont.

# Launching, Electrical system

All anti-fouling paints are poisonous and by definition more or less harmful to our marine environment. Avoid such products. Most countries have a legislation which controls the usage of anti-fouling boat bottom paints. **Always make sure you follow these regulations!** In some countries it is forbidden to use anti-fouling paints on leisure crafts, e.g. in freshwater.

We recommend simple Teflon treatment in combination with mechanical cleaning a few times during the season, especially in the case of smaller boats which are easy to lift.

This may be impractical for larger boats. Also, if the boat is in water which promotes fouling, an anti-fouling paint may need to be used after all. In this case, use a pure copper-based anti-fouling paint which contains copper thiocyanate (**not copper oxide**).

**Tin-based paints (TBT paints) must not be used!**

**Bear in mind the legislation in force for the area in which the boat is used.**

**NB.** Unsuitable bottom paints may cause great corrosion damage to the S-drive.

**Warning!** Do not paint the zinc anode (zinc ring) in front of the propeller. Leave a 10 mm (0.4 in) margin without anti-fouling paint around the S-drive.

Launch the boat when the paint has dried.

## Electrical system

**Warning!** Stop the engine and cut the power using the main switches before working on the electrical system.

### Batteries

**NB:** Follow the stipulated safety regulations when charging batteries. Always break the charging current before the charging clamps are removed.

**Warning!** When charging, the batteries give off hydrogen gas which forms oxyhydrogen gas with air. This gas is inflammable and extremely explosive.

Always use protective goggles and gloves when handling batteries.

The battery electrolyte contains strongly corrosive acid. Should this acid come into contact with the skin, wash with soap and plenty of water. Should the battery acid come into contact with the eyes, immediately rinse with copious amounts of water and contact your doctor immediately.

### Fuses

Two blocks of fuses of four fuses each (15A) for plus (+) and minus (-) are located on the relay box at the back of the lefthand side of the engine. The fuses break the current in the event of overloading.

Re-couple the electrical system if a fuse has burnt out by moving the cable connection to the next contact.

Always investigate the cause of the overload.

**Ensure that you always have spare fuses available.**

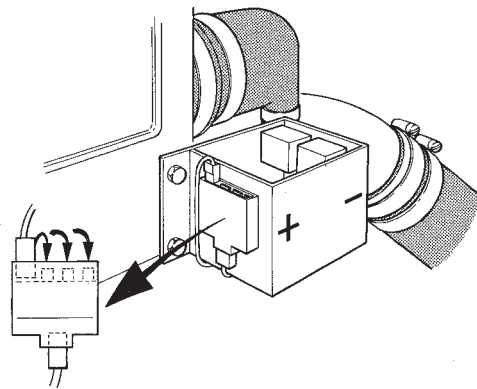

Fuses (15A)



## Standard instrument panels ("A" and "B")

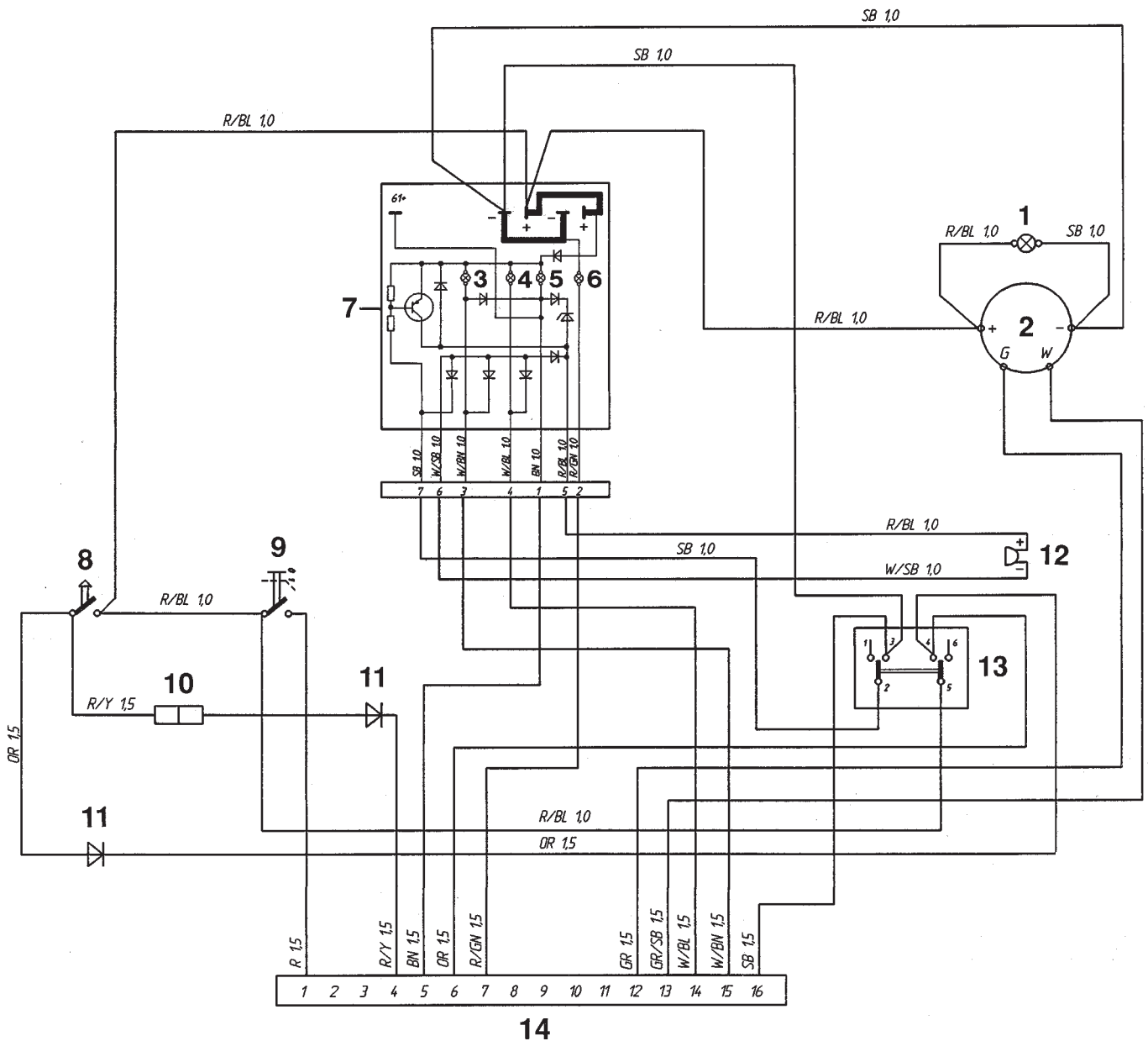

- |   |  |
|---|--|
| 1. Instrument lighting                      | 10. Connector for connecting neutral position switch, if applicable (extra equip.) |
| 2. Rev. counter/blind plug*                 | 11. Semiconductor diode  |
| 3. Warning light, coolant temperature       | 12. Alarm  |
| 4. Warning light, oil pressure              | 13. Toggle switch. Heating/Alarm test  |
| 5. Warning light, charging                  | 14. 16-pole connection   |
| 6. Control light, heating                   | * The blind plug is for instrument panel "B".                                      |
| 7. Electronic unit (alarm)                  |  |
| 8. Starter button                           |  |
| 9. Pressure switch. Instrument panel In/Out |  |

### Wire colours

- |     |   |             |
|-----|---|-------------|
| BL  | = | Blue        |
| LBL | = | Light blue  |
| BN  | = | Brown       |
| LBN | = | Light brown |
| GN  | = | Green       |
| GR  | = | Grey        |
| OR  | = | Orange      |
| PU  | = | Purple      |
| R   | = | Red         |
| SB  | = | Black       |
| W   | = | White       |
| Y   | = | Yellow      |

# De luxe instrument panel ("C")

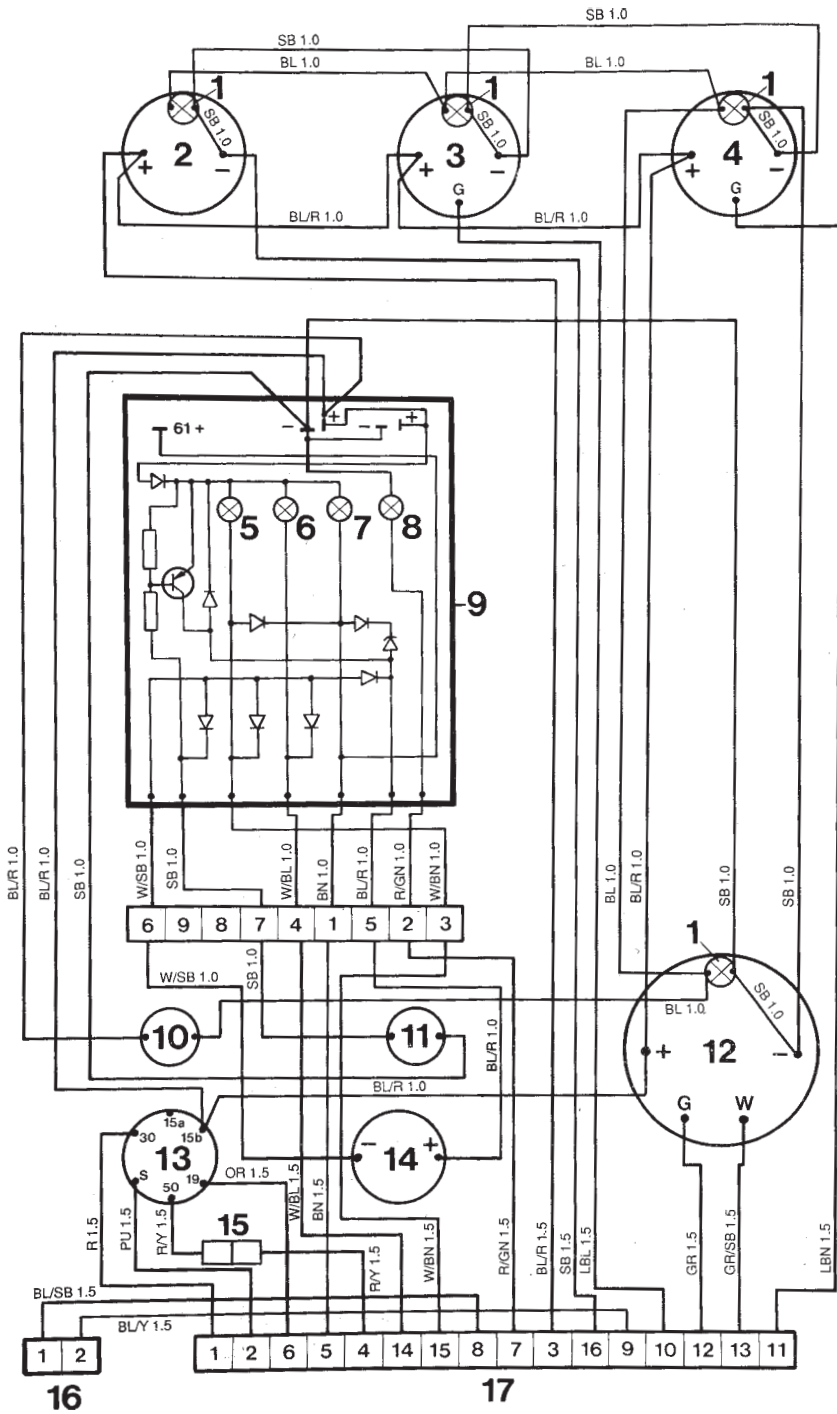

1. Instrument lighting
2. Voltmeter
3. Oil pressure gauge
4. Coolant temperature gauge
5. Warning light, coolant temperature
6. Warning light, oil pressure
7. Warning light, charging
8. Control light, heating
9. Electronic unit (alarm)
10. Switch, instrument lighting
11. Switch, alarm test
12. Rev. counter
13. Key switch
14. Alarm
15. Connection for connecting neutral position switch, if applicable (extra equip.)
16. 2-pole connection (for additional panel, if applicable)
17. 16-pole connection

## Wire colours

- BL = Blue
- LBL = Light blue
- BN = Brown
- LBN = Light brown
- GN = Green
- GR = Grey
- OR = Orange
- PU = Purple
- R = Red
- SB = Black
- W = White
- Y = Yellow

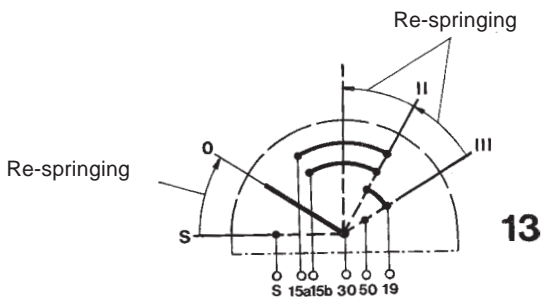

# Engines MD2010, MD2020, MD2030, MD2040

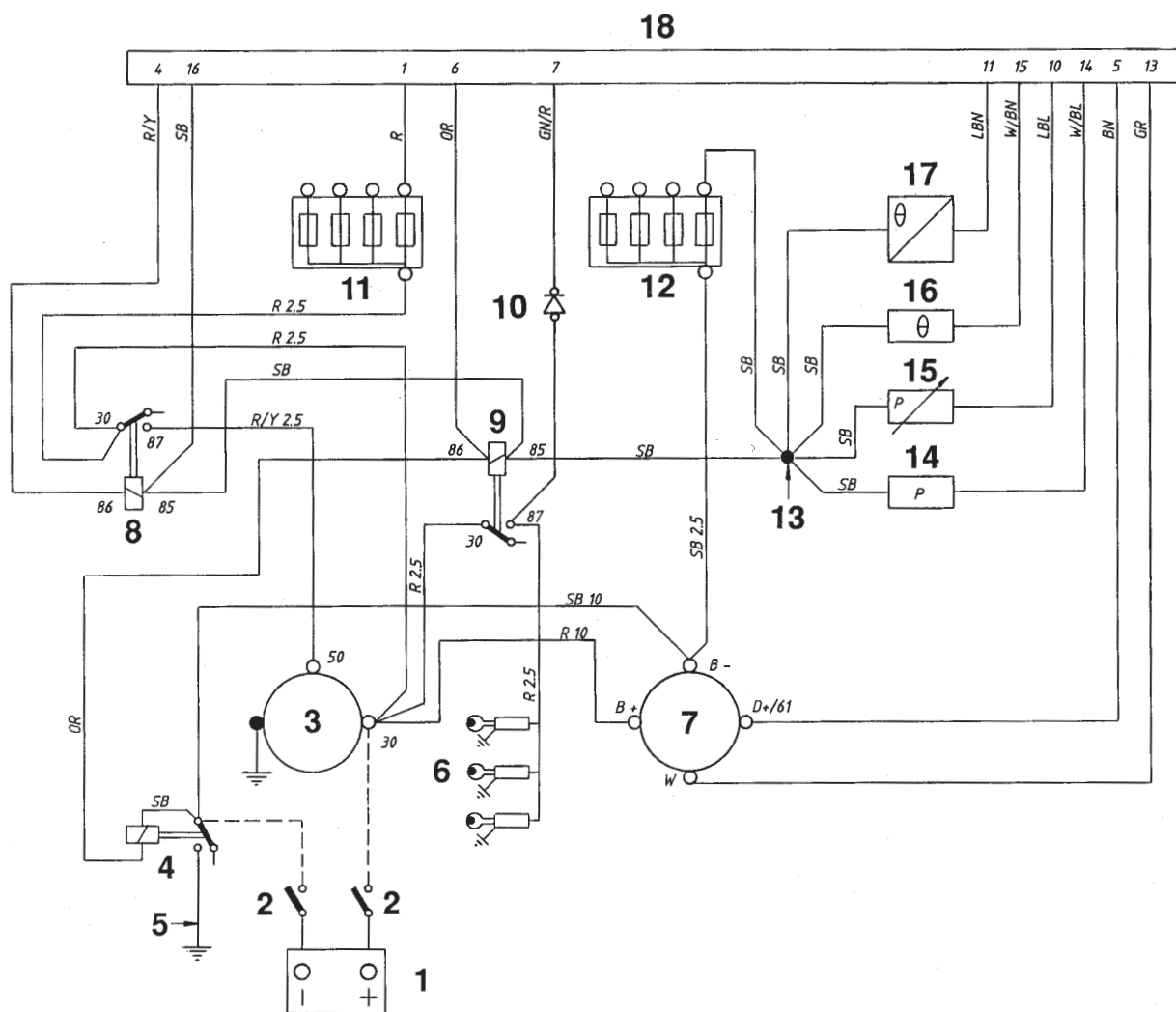

- 1. Battery
- 2. Main switch
- 3. Starter motor
- 4. Earthing relay
- 5. Earth rail
- 6. Glow plugs\*
- 7. Alternator
- 8. Start relay
- 9. Glow relay
- 10. Protective diode
- 11. Fuses (x 4), max. 15A
- 12. Fuses (x 4), max. 15A
- 13. Junction
- 14. Oil pressure switch, engine (normally open, closes at  $0.3 \pm 0.1$  bar)
- 15. Oil pressure sender
- 16. Coolant temperature switch (normally open, closes at  $95^\circ \pm 3^\circ\text{C}$  =  $203^\circ \pm 5^\circ\text{F}$ )
- 17. Coolant temperature sender
- 18. Connector, 16-pole

\* MD 2010: x 2. Other engines: x 3.

## Cable colours

- |                   |             |
|-------------------|-------------|
| BL = Blue         | OR = Orange |
| LBL = Light blue  | R = Red     |
| BN = Brown        | SB = Black  |
| LBN = Light brown | W = White   |
| GN = Green        | Y = Yellow  |
| GR = Grey         |             |

**Cable areas in mm<sup>2</sup> are stated after the colour code in the wiring diagram. Where no area is stated 1.5 mm<sup>2</sup> applies**

**Volvo Penta does not supply the dashed wires.**

## Relation mm<sup>2</sup> /AWG\*

\* American Wiring Gauge

mm <sup>2</sup>	1.0	1.5	2.5	10	16
AWG	16 (17)	15 (16)	13	7	5

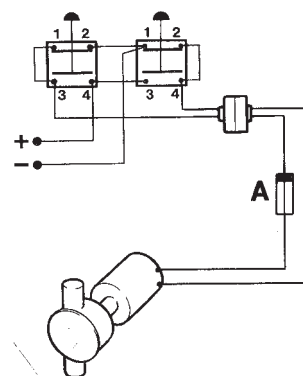

**Proposal for connection of oil bilge pump (draining and filling)**

Wire area 1.5 mm<sup>2</sup>.

A. Fuse (15A).

# Technical data

## General

	<b>MD2010</b>	<b>MD2020</b>	<b>MD2030</b>	<b>MD2040</b>
Engine designation .....	<b>MD2010</b>	<b>MD2020</b>	<b>MD2030</b>	<b>MD2040</b>
No. of cylinders .....	2	3	3	3
Bore .....	67 mm (2.638 in)	67 mm (2.638 in)	75 mm (2.953 in)	84 mm (3.307 in)
Stroke .....	64 mm (2.520 in)	64 mm (2.520 in)	72 mm (2.835 in)	90 mm (3.543 in)
Swept volume, total .....	0.45 litre (27.5 in <sup>3</sup> )	0.68 litre (41.3 in <sup>3</sup> )	0.95 litre (58.2 in <sup>3</sup> )	1.50 litres (91.3 in <sup>3</sup> )
Output, see sales literature				
Idling speed .....	850 ±25 r/min.	850 ±25 r/min.	850 ±25 r/min.	850 ±25 r/min.
Compression ratio .....	23.5:1	23.5:1	23:1	22:1
Direction of rotation, seen from the front .....	Clockwise	Clockwise	Clockwise	Clockwise
Max. permissible tilt backwards during operation	20°	20°	20°	20°
Max. side tilt during operation .....	30°	30°	30°	30°
Valve clearance, stationary cold engine:				
inlet and outlet .....	0.20 mm (0.008 in)	0.20 mm (0.008 in)	0.20 mm (0.008 in)	0.20 mm (0.008 in)
Weight, engine without oil and water .....	98 kg (216 lbs)	116 kg (256 lbs)	129 kg (285 lbs)	179 kg (395 lbs)

## Fuel system

Start of injection, crankshaft position .....	25.5° ±1° BTDC	25.5° ±1° BTDC	22.5° ±1° BTDC	21° ±1° BTDC
Injectors, opening pressure (when checking) ...	11.3-12.3 MPa (115-125 kp/cm <sup>2</sup> = 1639- 1784 lbf/in <sup>2</sup> )	11.3-12.3 MPa (115-125 kp/cm <sup>2</sup> =1639- 1784 lbf/in <sup>2</sup> )	11.3-12.3 MPa (115-125 kp/cm <sup>2</sup> = 1639- 1784 lbf/in <sup>2</sup> )	15.2-16.2 MPa (155-165 kp/cm <sup>2</sup> =2205- 2347 lbf/in <sup>2</sup> )
opening pressure (when setting) .....	11.8 MPa (120 kp/cm <sup>2</sup> 1711 lbf/ in <sup>2</sup> )	11.8 MPa (120 kp/cm <sup>2</sup> 1711 lbf/ in <sup>2</sup> )	11.8 MPa (120 kp/cm <sup>2</sup> 1711 lbf/ in <sup>2</sup> )	15.7 MPa (160 kp/cm <sup>2</sup> 2276 lbf/ in <sup>2</sup> )

## Lubricating system

Oil capacity, inc. oil filter, approx.:				
no engine tilt .....	1.8 litres (3.2 Imp. pints/ 1.9 US quarts)	3.4 litres (6.0 Imp. pints/ 3.6 US quarts)	4.3 litres (7.6 Imp. pints/ 4.5 US quarts)	7.3 litres (12.8 Imp. pints/ 7.7 US quarts)
Oil quality according to the API-system .....	CD	CD	CD	CD
Viscosity at -5° - +50°C* .....	SAE 15W/40 SAE 20W/50	SAE 15W/40 SAE 20W/50	SAE 15W/40 SAE 20W/50	SAE 15W/40 SAE 20W/50
Oil drain plug, tightening torque .....	30-40 Nm (3.0-4.0 kpm = 21.7-28.9 lbf. ft)	30-40 Nm (3.0-4.0 kpm = 21.7-28.9 lbf. ft)	30-40 Nm (3.0-4.0 kpm = 21.7-28.9 lbf. ft)	30-40 Nm (3.0-4.0 kpm = 21.7-28.9 lbf. ft)

\*Note! The temperature values bear reference to a constant ambient temperature.

## Cooling system

Thermostat, No. ....	1	1	1	1
The thermostat begins to open at .....	75° ±2°C (167° ±4°F)	75° ±2°C (167° ±4°F)	82° ±2°C (167° ±4°F)	82° ±2°C (167° ±4°F)
completely open at .....	87°C (189°F)	87°C (189°F)	95°C (203°F)	95°C (203°F)
Freshwater system capacity, approx .....	2.1 litres (3.7 Imp. pints/ 2.2 US quarts)	3.0 litres (5.3 Imp. pints/ 3.2 US quarts)	4.0 litres (7.0 Imp. pints/ 4.2 US quarts)	6.9 litres (12.1 Imp. pints/ 7.3 US quarts)

## Electrical system

	<b>MD2010</b>	<b>MD2020</b>	<b>MD2030</b>	<b>MD2040</b>
System voltage .....	12 V	12 V	12 V	12 V
Fuses .....	15A	15A	15A	15A
Battery capacity (starter battery) .....	70 Ah	70 Ah	70 Ah	70 Ah
Alternator, voltage/max. amperage .....	14V/60A	14V/60A	14V/60A	14V/60A
output approx. ....	840 W	840 W	840 W	840 W
Starter motor, output approx. ....	0.7 kW	0.7 kW	1.2 kW	2.0 kW

## Reverse gear

	<b>MS2L-D</b>	<b>MS2A-D</b>
Type designations .....	MS2L-D	MS2A-D
Gear ratios .....	2.3:1	2.37:1; 3.0:1
Angle (output shaft) .....	0°	7°
Oil capacity, approx. ....		0.8 litre (1.4 Imp. pints/ 0.85 US quarts)
Oil quality in accordance with the API system .		CD
Viscosity .....		SAE 15W/40
Weight .....		17 kg (37.5 lbs)
Tightening torque:		
oil drain plug .....		20 ±5 Nm (2 ±0.5 kpm 14.5 ±4 lbf.ft)

## S-drive

Type designation .....	<b>120S-D</b>
Gear ratio .....	2.48:1
Oil capacity, approx. ....	2.8 litres (4.9 Imp pints/3.0 US quarts)
volume difference min.- max. ....	0.07 litre (0.12 Imp pints/0.07 US quarts)
Oil quality in accordance with the API system .	CD
Viscosity .....	SAE 15W/40
Weight .....	28 kg (61.7 lbs)
Tightening torque:	
oil drain plug .....	10 ±5 Nm (1 ±0.5 kpm = 7.2 ±4 lbf.ft)

# Troubleshooting

## Troubleshooting schedule – engine

Engine does not start	Engine stops	Does not reach full speed	Runs unevenly, vibrates	Gets abnormally hot	Cause of fault
●					Check the batteries, electric wires, main switches.
●	●	●	●		Check amount of fuel, fuel cocks, fuel filter and fuel (for any impurities, water, air).
		●	●		Faulty injectors.
		●			Boat abnormally loaded, fouling on the bottom of the boat.
		●			Blocked air filter.
			●		Damage to propeller.
				●	Blocked cooling water intake, blocked seawater filter, coolant level too low, air in the freshwater system, defective impeller or thermostat.

**Owner**

Name: ..... Tel: .....

Address: .....

**Nearest Volvo Penta Service Dealer**

Name: ..... Tel: .....

Address: .....

**Engine**

Engine type: .....

Serial No.: .....

**Reverse gear/S-drive**

Type: ..... Ratio: .....

Serial No.: .....

