

TAD1641/1642GE-B

16.12 liter, in-line 6 cylinder

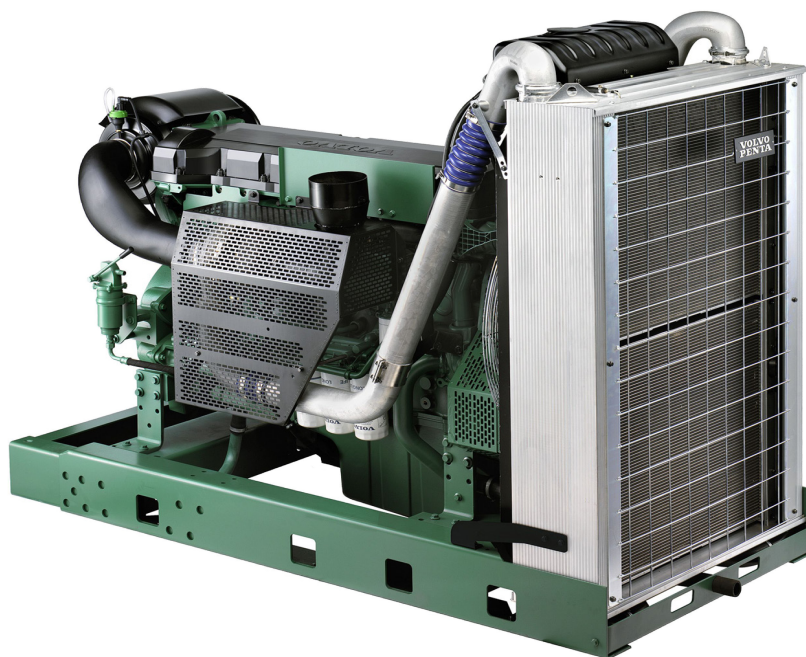

TAD1641GE-B and TAD1642GE-B are powerful, reliable and economical Generating Set Diesel Engines built on the dependable in-line six design.

Durability and low noise

Designed for easiest, fastest and most economical installation. Well-balanced to produce smooth and vibration-free operation with low noise level.

To maintain a controlled working temperature in cylinders and combustion chambers, the engine is equipped with piston cooling. The engine is also fitted with replaceable cylinder liners and valve seats/guides to ensure maximum durability and service life of the engine.

Low exhaust emission

The state of the art, high-tech injection and charging system with low internal losses contributes to excellent combustion and low fuel consumption.

The TAD1641GE-B and TAD1642GE-B complies with EU Stage 2 exhaust emission regulations.

Easy service and maintenance

Easily accessible service and maintenance points contribute to the ease of service of the engine.

- Fully electronic with Volvo Penta EMS 2.4
- Dual frequency switch (between 1500 rpm and 1800 rpm)
- RoHS2 compliant
- High power density
- Emission compliant
- Low noise levels
- Gen Pac configuration

	50 Hz / 1500 rpm									60 Hz / 1800 rpm								
	Continuous power			Prime power			Standby power			Continuous power			Prime power			Standby power		
	kWm	kWe	kVA	kWm	kWe	kVA	kWm	kWe	kVA	kWm	kWe	kVA	kWm	kWe	kVA	kWm	kWe	kVA
TAD1641GE-B	323	303	379	432	406	508	475	446	558	364	342	428	489	460	575	550	517	646
TAD1642GE-B	377	355	443	505	475	593	556	523	653	399	375	469	536	504	630	589	554	692

Data Center Power	50 Hz / 1500 rpm						60 Hz / 1800 rpm					
	>300h running per year or non-reliable utility power in the country			≤300h running per year and reliable utility power in the country			>300h running per year or non-reliable utility power in the country			≤300h running per year and reliable utility power in the country		
	kWm	kWe	kVA	kWm	kWe	kVA	kWm	kWe	kVA	kWm	kWe	kVA
TAD1641GE-B	432	406	508	475	446	558	489	460	575	550	517	646
TAD1642GE-B	505	475	593	556	523	653	536	504	630	589	554	692

Generator efficiency (typical): 94%

kWm = kiloWatt mechanical, net with fan*; kWe = kiloWatt electrical = kWm x Generator eff.; kVA = kiloVoltAmpere calculations based on a 0.8 power factor = kWe / 0.8

1 kW = 1 hp x 1.36; 1 hp = 1 kW x 0.7355

*) According to technical data

TAD1641/1642GE-B

16.12 liter, in-line 6 cylinder

Technical Data

Configuration and no. of cylinders	in-line 6
Method of operation	4-stroke
Bore, mm (in.)	144 (5.67)
Stroke, mm (in.)	165 (6.50)
Displacement, l (in ³)	16.12 (983.7)
Compression ratio	16.5:1
Dry weight, kg (lb)	1480 (3263)
Dry weight with Gen Pac, kg (lb)	1910 (4211)
Wet weight, kg (lb)	1550 (3417)
Wet weight with Gen Pac, kg (lb)	2020 (4453)

	TAD1641GE-B		TAD1642GE-B	
	1500 rpm	1800 rpm	1500 rpm	1800 rpm
Prime Power, kW (hp)	432 (588)	489 (665)	505 (687)	536 (729)
Standby Power, kW (hp)	475 (646)	550 (748)	556 (756)	589 (801)

Fuel consumption

Prime Power, g/kWh (lb/hph)

	TAD1641GE-B		TAD1642GE-B	
	1500 rpm	1800 rpm	1500 rpm	1800 rpm
25%	233 (0.378)	249 (0.403)	219 (0.356)	234 (0.380)
50%	205 (0.332)	210 (0.341)	198 (0.321)	203 (0.329)
75%	201 (0.326)	205 (0.332)	196 (0.318)	202 (0.327)
100%	200 (0.325)	207 (0.335)	193 (0.313)	204 (0.330)

Standby Power, g/kWh (lb/hph)

	TAD1641GE-B		TAD1642GE-B	
	1500 rpm	1800 rpm	1500 rpm	1800 rpm
25%	227 (0.368)	232 (0.376)	215 (0.348)	296 (0.480)
50%	203 (0.328)	202 (0.327)	197 (0.320)	202 (0.327)
75%	200 (0.324)	203 (0.329)	198 (0.322)	205 (0.332)
100%	197 (0.319)	204 (0.331)	196 (0.317)	206 (0.334)

Dimensions

Not for installation. Dimensions in mm.

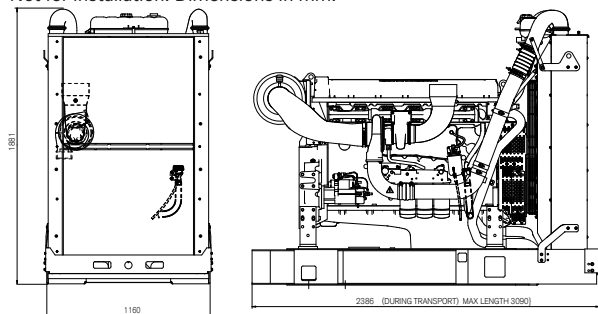

Rating guidelines

CONTINUOUS POWER is defined as being the maximum power which the generating set is capable of delivering continuously while supplying a constant electrical load when operated for an unlimited number of hours per year under the agreed operating conditions with the maintenance intervals and procedures being carried out as prescribed by the manufacturer.

PRIME POWER rating corresponds to ISO Standard Power for continuous operation. It is applicable for supplying electrical power at variable load for an unlimited number of hours instead of commercially purchased power. A10 % overload capability for governing purpose is available for this rating.

STAND-BY POWER rating corresponds to ISO Standard Fuel Stop Power. It is applicable for supplying stand-by electrical power at variable load in areas with well established electrical networks in the event of normal utility power failure. No overload capability is available for this rating.

DATA CENTRE POWER is defined as being the maximum power which a generating set is capable of delivering while supplying a variable or continuous electrical load and during unlimited run hours. Depending on the sites to supply and the availability of reliable utility, the generating set manufacturer is responsible to define what power level he is able to supply to fulfil that requirement including hardware or software or maintenance plan adaptation.

Technical description

Engine and block

- Optimized cast iron cylinder block with optimum distribution of forces without the block being unnecessary heavy.
- Wet, replaceable cylinder liners
- Piston cooling for low thermal load on pistons and reduced ring temperature
- Tapered connecting rods to reduce risk of piston cracking
- Crankshaft induction hardened bearing surfaces and fillets with seven main bearings for moderate load on main and big-end bearings
- Nitrocarburized transmission gears for heavy duty operation
- Keystone top compression rings for long service life
- Viscous type crankshaft vibration damper
- Replaceable valve guides and valve seats
- Over head camshaft and four valves per cylinder equipped with camshaft damper to reduce noise and vibrations.

Lubrication system

- Full flow oil cooler
- Full flow disposable spin-on oil filters, for extra high filtration
- The lubricating oil level can be measured during operation (Standard dipstick only)
- Gear type lubricating oil pump, gear driven by the transmission

Fuel system

- Self de-aerating system. When replacing filters all fuel stays in the engine.
- Non-return fuel valve
- Electronic unit injectors
- Fuel prefilter with water separator and water-in-fuel indicator / alarm
- Gear driven low-pressure fuel pump
- Fine fuel filter with manual feed pump and fuel pressure switch
- Fuel shut-off valve, electrically operated

Cooling system

- Efficient cooling with accurate coolant control through a water distribution duct in the cylinder block. Reliable sleeve thermostat with minimum pressure drop
- Belt driven, maintenance-free coolant pump with high degree of efficiency

Turbo charger

- Efficient and reliable turbo charger
- Extra oil filter for the turbo charger

Electrical system

- Engine Management System 2 (EMS 2.4), an electronically controlled processing system which optimizes engine performance. It also includes advanced facilities for diagnostics and fault tracing
- The instruments and controls connect to the engine via the CAN SAE J1939 interface, either through the Control Interface Module (CIM) or the Digital Control Unit (DCU). The CIM converts the digital CAN bus signal to an analog signal, making it possible to connect a variety of instruments. The DCU2 is a control panel with display, engine control, monitoring, alarm, parameter setting and diagnostic functions. The DCU2 also presents error codes in clear text.
- Sensors for oil pressure, oil temp, boost pressure, boost temp, coolant-temp, fuel temp, water in fuel, fuel pressure and two speed sensors. Crank case pressure, piston cooling pressure, oil level and air filter pressure drop sensors.
- Alternator 24V / 80A

Power standards

The engine performance corresponds to ISO 3046, BS 5514 and DIN 6271. The technical data applies to an engine without cooling fan and operating on a fuel with calorific value of 42.7 MJ/kg (18360 BTU/lb) and a density of 0.84 kg/liter (7.01 lb/US gal), also where this involves a deviation from the standards. Ratings are based on ISO 8528. Engine speed governing in accordance with ISO 8528-5 G3.

Please note that products illustrated may differ from production models. Not all models and accessories are available in all markets, and standard equipment may vary between different markets. Every effort has been made to ensure that facts and figures are correct at the time of publication. However, Volvo Penta reserves the right to make changes without prior notice at any time.

Please contact your local Volvo Penta dealer for further information.



AB Volvo Penta

SE-405 08 Göteborg, Sweden
www.volvopenta.com