

TWD1683GE

16.12 liter, in-line 6 cylinder

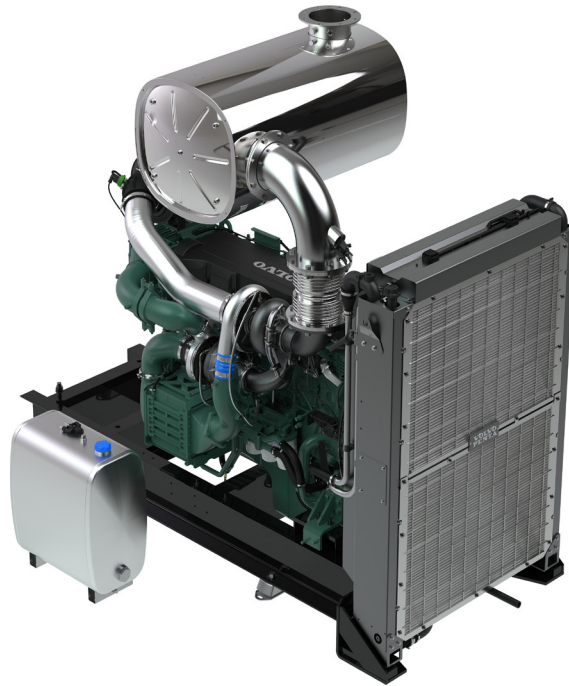

TWD1683GE is a reliable, powerful and compact in-line 6 cylinder diesel engine. It is designed to power a wide range of stand-by and prime power generator sets.

This 16 liter diesel engine utilizes dual-stage turbochargers and heavy-duty steel pistons to provide excellent power density. It features a proven combustion technology with high-pressure unit injectors, resulting in high fuel efficiency and low exhaust emission levels.

Efficient injection as well as robust engine design in combination with SCR technology (Selective Catalyst Reduction) contributes to low exhaust emission, excellent combustion and low fuel consumption.

The exhaust aftertreatment system consists of only SCR, without EGR, DOC or DPF. A minimum of components are used and no downtime for regeneration or decreased service intervals. No EGR also results in less heat rejection, leading to excellent power density and improved fuel economy.

SCR technology selected by Volvo Group does not increase the amount of cooling capacity needed.

The engine also features a compact and low weight design that is well-balanced, providing smooth operation with low noise and vibration. It is designed for easily accessible service points. A wide range of options is available, including a heavy-duty frame, cooling package and air-filter that will suit a variety of installations.

- Proven and straight-forward design - built on Volvo Group technology
- RoHS2 Compliant
- Low cost of ownership and operation
- SCR only - no EGR, DOC, DPF or regeneration
- High efficient cooling system
- Excellent step load performance acc. to ISO 8528-5
- Compact, simple installation and easy to service
- Available as Genpac or Base engine configuration

50 Hz / 1500 rpm

	Prime power			Standby power		
	kWm	kWe	kVA	kWm	kWe	kVA
TWD1683GE	570	536	670	627	589	737

60 Hz / 1800 rpm

	Prime power			Standby power		
	kWm	kWe	kVA	kWm	kWe	kVA
TWD1683GE	596	560	700	655	616	770

50 Hz / 1500 rpm

Data Center Power	>300h running per year or non-reliable utility power in the country			≤300h running per year and reliable utility power in the country		
	kWm	kWe	kVA	kWm	kWe	kVA
TWD1683GE	570	536	670	627	589	737

60 Hz / 1800 rpm

Data Center Power	>300h running per year or non-reliable utility power in the country			≤300h running per year and reliable utility power in the country		
	kWm	kWe	kVA	kWm	kWe	kVA
TWD1683GE	596	560	700	655	616	770

Generator efficiency (typical): 94%

kWm = kiloWatt mechanical, net with fan*; kWe = kiloWatt electrical = kWm x Generator eff.; kVA = kiloVoltAmpere calculations based on a 0.8 power factor = kWe / 0.8

1 kW = 1 hp x 1.36; 1 hp = 1 kW x 0.7355

*) According to technical data

TWD1683GE

16.12 liter, in-line 6 cylinder

Technical Data

Configuration and no. of cylinders	in-line 6
Displacement, l (in ³)	16.12 (983.9)
Method of operation	4-stroke
Bore, mm (in.)	144 (5.67)
Stroke, mm (in.)	165 (6.50)
Compression ratio	16.8:1
Wet weight, engine only, kg (lb)	1810 (3990)
Wet weight, Genpac (engine, cooling system, air filtration system and frame kg (lb))	2767 (6100)

Fuel consumption

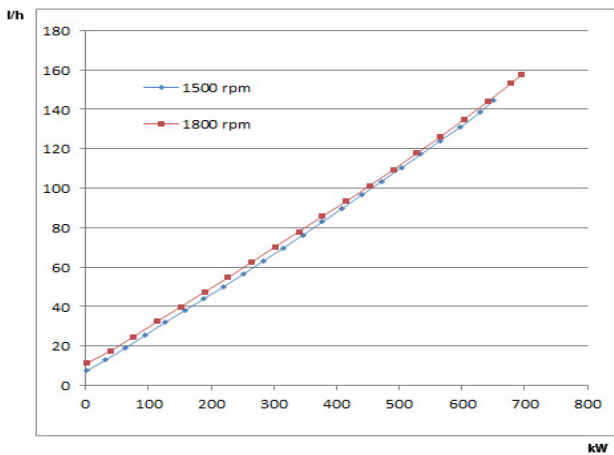

Dimensions

Not for installation. Dimensions in mm [inch].

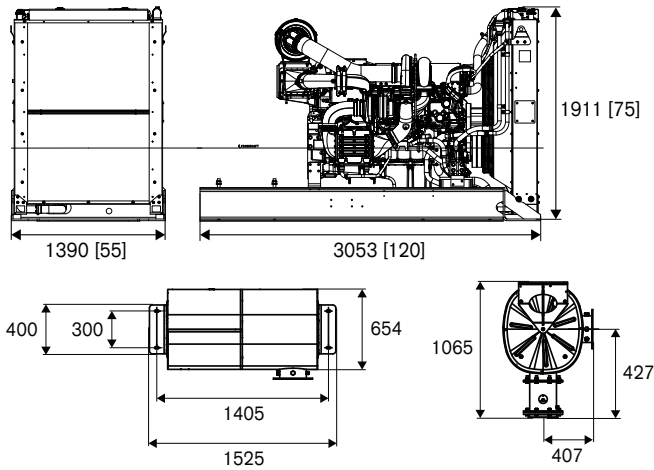

Technical description

Engine and block

- Cast iron cylinder block with optimum distribution of forces
- Wet, replaceable cylinder liners
- Tapered connecting rods for increased piston lifetime
- Crankshaft induction hardened bearing surfaces and fillets with seven main bearings
- Case hardened and Nitrocarburized transmission gears for heavy duty operation
- Viscous type crankshaft vibration dampers to withstand single bearing alternator torsional vibrations
- Replaceable valve guides and valve seats
- Overhead camshaft and 4 valves per cylinder

Lubrication system

- Full flow oil cooler
- Full flow disposable spin-on oil filter, for extra high filtration
- The lubricating oil level can be measured at start-up

Fuel system

- Electronic high pressure unit injectors
- Fuel prefilter with water separator and water-in-fuel indicator / alarm
- Fine fuel filter with manual feed pump and fuel pressure switch

Cooling system

- Efficient cooling with accurate coolant control through a water distribution duct in the cylinder block
- Belt driven coolant pumps with high degree of efficiency
- Water-cooled charge air coolers

Turbo charger

- Efficient and reliable dual stage turbo chargers
- Intermediate charge air coolers for both turbo chargers
- Waste gate system for the high pressure turbo charger

Electrical system

- Engine Management System (EMS), an electronically controlled processing system which optimizes engine performance. It also includes advanced facilities for diagnostics and fault tracing
- The instruments and controls connect to the engine via the CAN SAE J1939 interface. The DCU2 is a control panel with display, engine control, monitoring, alarm, parameter setting and diagnostic functions. It also presents error codes in clear text. The DCU2 makes it possible to install and combine several sets of analogue and digital instruments.
- Sensors for oil pressure, oil temp, boost pressure, boost temp, coolant temp, fuel temp, water in fuel, fuel pressure and two speed sensors.

Exhaust aftertreatment system

- SCR only. No EGR, DOC, DPF or regeneration. Wide range of installation options available.
- AdBlue/DEF tank including AdBlue/DEF Quality Level Temperature Sensor

Rating guidelines

PRIME POWER rating corresponds to ISO Standard Power for continuous operation. It is applicable for supplying electrical power at variable load for an unlimited number of hours instead of commercially purchased power. A10 % overload capability for governing purpose is available for this rating.

STAND-BY POWER rating corresponds to ISO Standard Fuel Stop Power. It is applicable for supplying stand-by electrical power at variable load in areas with well established electrical networks in the event of normal utility power failure. No overload capability is available for this rating.

DATA CENTRE POWER is defined as being the maximum power which a generating set is capable of delivering while supplying a variable or continuous electrical load and during unlimited run hours. Depending on the sites to supply and the availability of reliable utility, the generating set manufacturer is responsible to define what power level he is able to supply to fulfil that requirement including hardware or software or maintenance plan adaptation.

Power standards

The engine performance corresponds to ISO 3046, BS 5514 and DIN 6271. The technical data applies to an engine without cooling fan and operating on a fuel with calorific value of 42.7 MJ/kg (18360 BTU/lb) and a density of 0.84 kg/liter (7.01 lb/US gal), also where this involves a deviation from the standards. Ratings are based on ISO 8528. Engine speed governing in accordance with ISO 8528-5 G3.

Please note that products illustrated may differ from production models. Not all models and accessories are available in all markets, and standard equipment may vary between different markets. Every effort has been made to ensure that facts and figures are correct at the time of publication. However, Volvo Penta reserves the right to make changes without prior notice at any time.

Please contact your local Volvo Penta dealer for further information.



AB Volvo Penta
SE-405 08 Göteborg, Sweden
www.volvopenta.com