

TAD550-552VE

5.13 liter, in-line 4 cylinder - 105, 129 & 160 kW
 UNECE Reg 96 Power band H (equal to EU Stage IIIA)



TAD550-552VE is a powerful, reliable and economical off-road Diesel Engine range built on the Volvo Group in-line four concept.

Low cost of ownership

World class fuel efficiency combined with high uptime as well as low cost of ownership.

Compact & simple installation

As optional equipment all material needed in order to install the engine can be ordered from Volvo Penta. Installation guidelines as well as drawings and CAD models are easy to access. The result is an engine that is easy to install.

Durability & low noise

Long experience with base engine development reduces risk of downtime. Well-balanced to produce smooth operation with low noise.

Power & torque

Maximum power and torque available at low rpm. As a result noise as well as fuel consumption is very low. Useful engine speed for the TAD550-552VE is due to power and torque layout very flexible.

Low exhaust emission

Efficient injection as well as robust engine design contributes to excellent combustion and low fuel consumption.

Easy service & maintenance

Easily accessible service and maintenance points contribute to the ease of service of the engine. As optional equipment possible to remote mount filters and service points. Up to 1000 hour oil change interval.

- Proven and straight-forward design - built on Volvo Group technology
- Low cost of ownership and operation
- High power and torque already at low engine speed
- Compact, simple installation and easy to service
- Exhaust reduction system without EGR
- Similar engine footprint for all emission standards
- High sulfur-in-fuel tolerance
- Wide range of optional equipment

	TAD550VE	TAD551VE	TAD552VE
Power output, kW/hp	105/143	129/175	160/218
at speed, rpm	2200	2200	2200
Max. torque, Nm/lb/ft	710/524	810/597	910/671
at speed, rpm	1400	1400	1450

TAD550-552VE

5.13 liter, in-line 4 cylinder - 105, 129 & 160 kW
 UNECE Reg 96 Power band H (equal to EU Stage IIIA)

Technical data

Configuration and no. of cylinders	in-line 4
Displacement, l (in ³)	5.13 (313)
Method of operation	4-stroke
Direction of rotation (viewed towards flywheel).....	anti-clockwise
Bore, mm (in.)	110 (4.33)
Stroke, mm (in.)	135 (5.31)
Compression ratio	17.5:1
Dry weight, engine only, kg (lb).....	556 (1226)

Technical description

Engine and block

- Cast iron cylinder block
- Replaceable cylinder liners
- Replaceable valve guides and valve seats
- Overhead camshaft and four valves per cylinder

Lubrication system

- Full flow cartridge insert filter
- Gear type lubricating oil pump, gear driven

Fuel system

- Common rail
- Gear driven fuel feed pump
- Fuel prefilter with water separator and water-in-fuel indicator / alarm
- Fine fuel filter of cartridge, insert type
- Manual feed pump on pre filter

Cooling system

- Belt driven coolant pump with high degree of efficiency

Turbo charger

- Fixed Geometry Turbo (FGT)

Electrical system

- Engine Management System (EMS), an electronically controlled processing system which optimizes engine performance. It also includes advanced features for diagnostics and fault tracing.
- The instruments and controls connect to the engine via the CAN SAE J1939 interface. Options available for engine control equipment.

Exhaust reduction system

- Without EGR

Dimensions

Not for installation. Dimensions in mm.

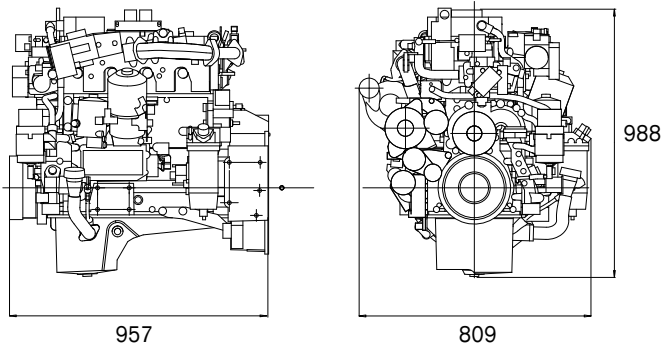

Characteristics

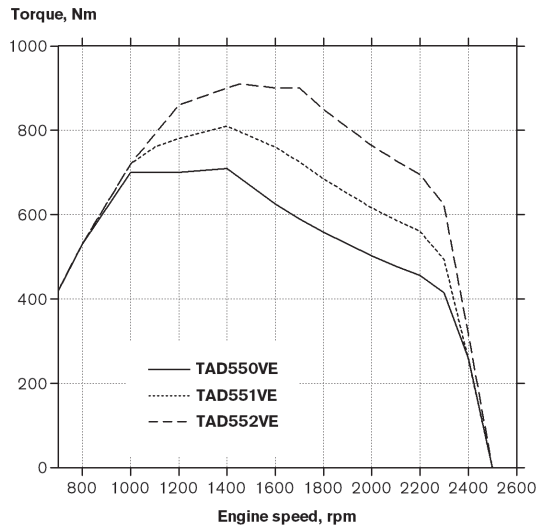
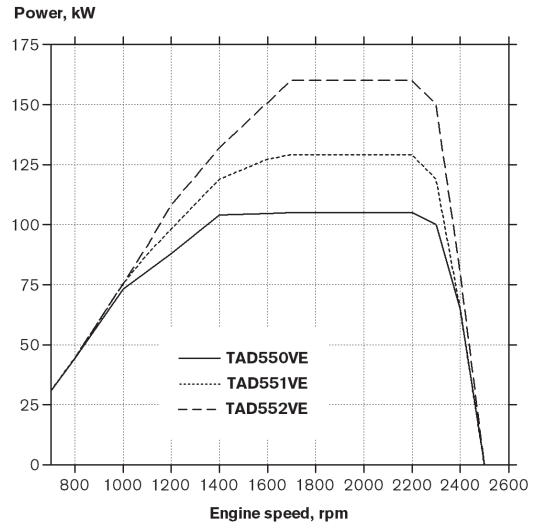

Fuel consumption

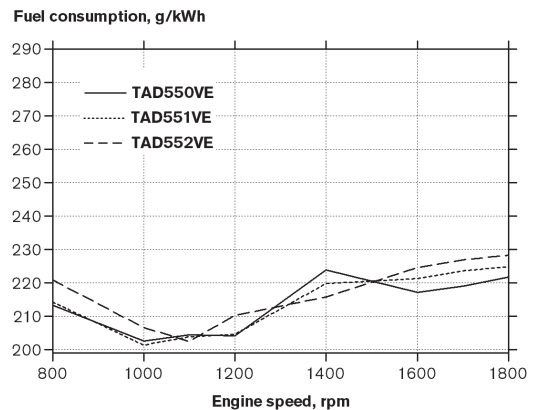

Power standards

The engine performance corresponds to ISO 3046, BS 5514 and DIN 6271. The technical data applies to an engine without cooling fan and operating on a fuel with calorific value of 42.7 MJ/kg (18360 BTU/lb) and a density of 0.84 kg/liter (7.01 lb/US gal, 8.42 lb/imp gal), also where this involves a deviation from the standards.

Additional information

For additional information, please contact your Volvo Penta representative or visit www.volvopenta.com.

Please note that products illustrated may differ from production models.

Not all models and accessories are available in all markets, and standard equipment may vary between different markets. Every effort has been made to ensure that facts and figures are correct at the time of publication. However, Volvo Penta reserves the right to make changes without prior notice at any time.

AB Volvo Penta

SE-405 08 Göteborg, Sweden
www.volvopenta.com