

TAD1140-1142VE

10.84 liter, in-line 6 cylinder - 235, 265 & 285 kW

UNECE Reg 96 Power band E (equal to EU Stage II) Certified for MSHA / CANMET (TAD1140-1141VE)

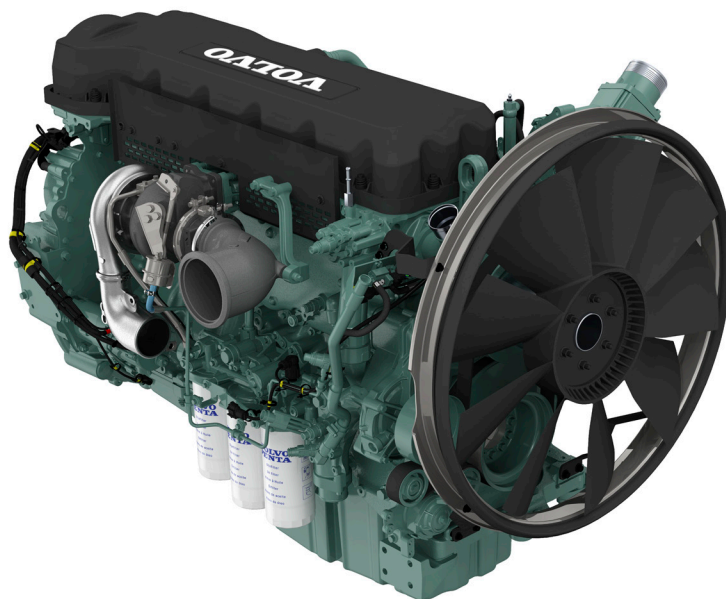

TAD1140-1142VE is a powerful, reliable and economical off-road Diesel Engine range built on the Volvo Group in-line six concept.

Low cost of ownership

World class fuel efficiency combined with high uptime as well as low cost of ownership.

Compact & simple installation

As optional equipment all material needed in order to install the engine can be ordered from Volvo Penta. Installation guidelines as well as drawings and CAD models are easy to access. The result is an engine that is easy to install.

Durability & low noise

Long experience with base engine development reduces risk of downtime. Well-balanced to produce smooth operation with low noise.

Power & torque

Maximum power and torque available at low rpm. As a result noise as well as fuel consumption is very low. Useful engine speed for the TAD1140-1142VE is due to power and torque layout very flexible.

Low exhaust emission

Efficient injection as well as robust engine design contributes to excellent combustion and low fuel consumption.

Easy service & maintenance

Easily accessible service and maintenance points contribute to the ease of service of the engine. As optional equipment possible to remote mount filters and service points.

- Proven and straight-forward design - built on Volvo Group technology
- Low cost of ownership and operation
- High power and torque already at low engine speed
- Compact, simple installation and easy to service
- Exhaust reduction system without EGR
- Similar engine footprint for all emission standards
- High sulfur-in-fuel tolerance
- Wide range of optional equipment

	TAD1140VE	TAD1141VE	TAD1142VE
Power output, kW/hp	235/320	265/360	285/388
at speed, rpm	2100	2100	1700
Max. torque, Nm/lb/ft	1581/1166	1785/1316	1938/1429
at speed, rpm	1260	1260	1260

TAD1140-1142VE

10.84 liter, in-line 6 cylinder - 235, 265 & 285 kW

UNECE Reg 96 Power band E (equal to EU Stage II) Certified for MSHA / CANMET (TAD1140-1141VE)

Technical data

Configuration and no. of cylinders	in-line 6
Displacement, l (in ³)	10.84 (661)
Method of operation	4-stroke
Direction of rotation (viewed towards flywheel).....	anti-clockwise
Bore, mm (in.)	123 (4.84)
Stroke, mm (in.)	152 (5.98)
Compression ratio	17.0:1
Dry weight, engine only, kg (lb).....	1036 (2284)

Technical description

Engine and block

- Cast iron cylinder block
- Wet, replaceable cylinder liners
- Replaceable valve guides and valve seats
- Overhead camshaft and four valves per cylinder

Lubrication system

- Full flow disposable spin-on oil filter, for extra high filtration
- Gear type lubricating oil pump, gear driven by the transmission
- Oil level sensor at startup

Fuel system

- Electronic high pressure unit injectors
- Fuel prefilter with water separator and water-in-fuel indicator / alarm
- Gear driven low-pressure fuel pump
- Fine fuel filter with manual feed pump and fuel pressure switch

Cooling system

- Available as power pack or base engine.
- Belt driven coolant pump with high degree of efficiency

Turbo charger

- Electronically controlled Waste-gate

Electrical system

- Engine Management System (EMS), an electronically controlled processing system which optimizes engine performance. It also includes advanced features for diagnostics and fault tracing.
- The instruments and controls connect to the engine via the CAN SAE J1939 interface. Options available for engine control equipment.

Exhaust reduction system

- Without EGR

Dimensions

Not for installation. Dimensions in mm.

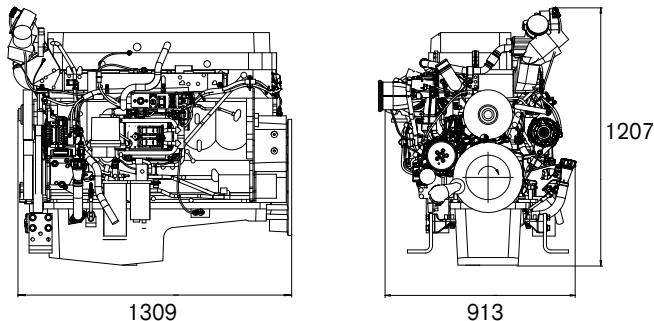

Characteristics

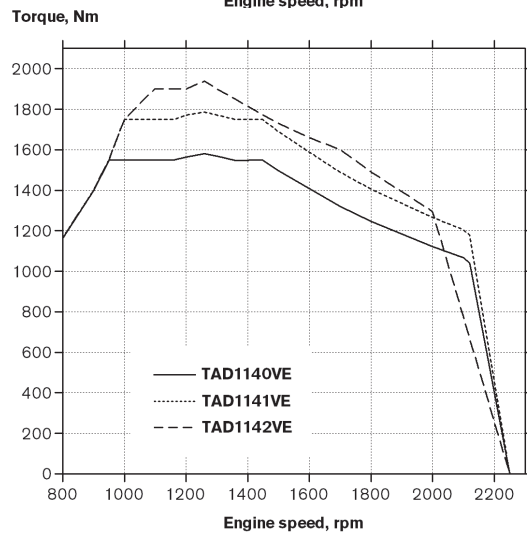
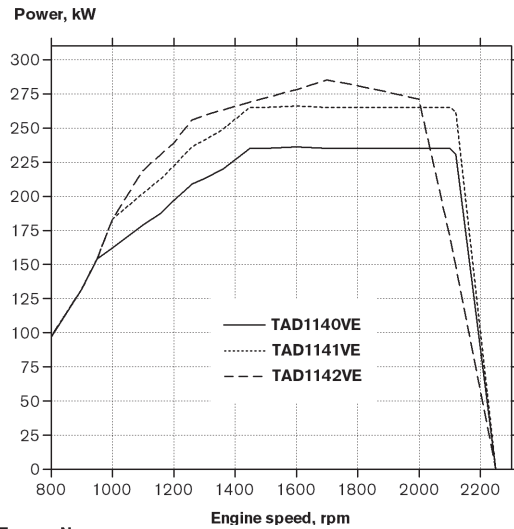

Fuel consumption

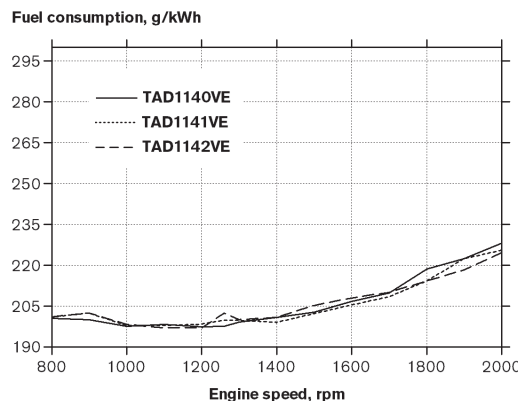

Power standards

The engine performance corresponds to ISO 3046, BS 5514 and DIN 6271. The technical data applies to an engine without cooling fan and operating on a fuel with calorific value of 42.7 MJ/kg (18360 BTU/lb) and a density of 0.84 kg/liter (7.01 lb/US gal, 8.42 lb/Imp gal), also where this involves a deviation from the standards.

Additional information

For additional information, please contact your Volvo Penta representative or visit www.volvopenta.com.

Please note that products illustrated may differ from production models.

Not all models and accessories are available in all markets, and standard equipment may vary between different markets. Every effort has been made to ensure that facts and figures are correct at the time of publication. However, Volvo Penta reserves the right to make changes without prior notice at any time.

AB Volvo Penta

SE-405 08 Göteborg, Sweden
www.volvopenta.com