

## VOLVO PENTA MARINE GENSET

# D13-MG (FE)

12.78 liter, in-line 6 cylinder

310–430 kVA (248–344 kWe) at 1500rpm 50Hz/400V, 375–479 kVA (300–383 kWe) at 1800rpm 60Hz/440V

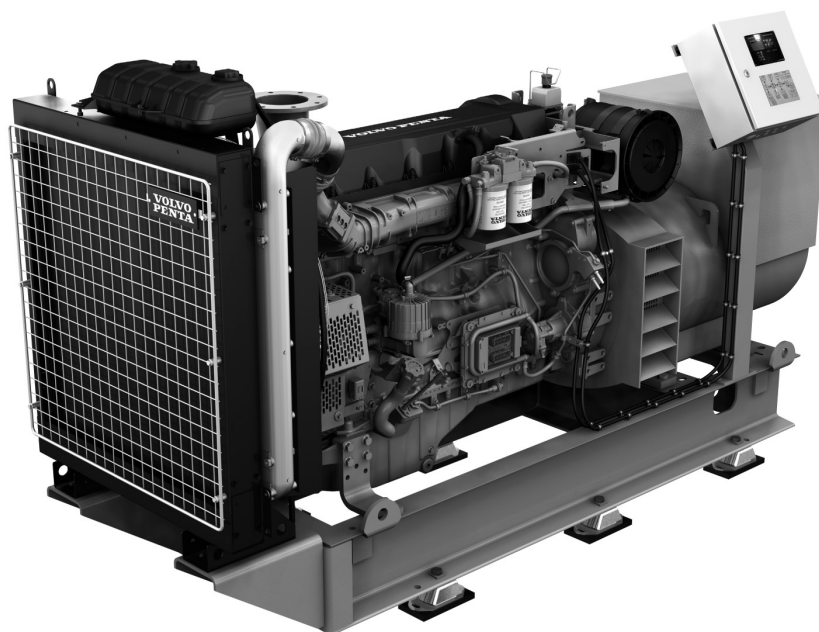

### Volvo Penta Genset system

The Volvo Penta Genset systems are the complete solution for a ship's onboard power requirements. You will not only get reliable marine diesels, well-matched generators and a monitoring system, but also a wide range of products and services to optimize your investment.

The basis for the Volvo Penta Gensets is the smooth running and reliable marine diesel engines. Compact in design, they occupy less space in the engine room, and their good accessibility makes service and maintenance easy. Auto-start and synchronizing is rapid and reliable, meeting all standards with a comfortable margin. Volvo's basic engine design in combination with a highly efficient speed control system gives superior load taking capability.

### Complete and classified

Each Volvo Penta Genset is built in the Volvo factory fully adapted to the customer's requirements and comes complete and tested, ready for installation onboard.

All the Volvo Penta Gensets are type approved by the major classification societies, and can be delivered under complete certification.

### Clean engine

The Volvo Penta engines are well balanced and have excellent emission performance. No visible smoke can be recognized. With growing care for the environment all over the world, emission regulations are becoming increasingly stricter. The D13 MG is certified for the comprehensive emission requirements according to EPA Tier 3, IMO Tier III, China 2 and EU IWW Stage V for diesel electric propulsion.

### Standard generator

All the standard Gensets are equipped with a generator built by Newage Stamford.

Stamford is the market leader in this power range and provides for worldwide service coverage. These generators are of a long proven design, based on years of experience of power generation for land-based and marine applications.

### Reduced noise

The noise level on the D13 MG has been further reduced due to variable injector pressure and a new efficient cooling system. The harbor and emergency gensets with radiator cooling system can offer even lower sound pressure with an optional visco fan.

### Marine control unit

Each complete genset is delivered with Volvo Penta MCU (Marine Control Unit) alarm and monitoring system with interface for connections to the switchboard and bridge.

For all classed gensets SDU (Shut down unit) will give full redundancy and safety according to SOLAS & class requirements.

### Trouble free service

Scheduled maintenance and preventive repairs will keep you from unnecessary and expensive downtime. For each genset application Volvo Penta dealers can offer extensive life cycle cost analysis including fuel and maintenance cost.

Qualified Volvo Penta dealers stand by for service and support in more than 100 countries all over the world. A complete set of documentation will be delivered with the set according to Volvo's high quality publication standard.

The optional extended coverage (CXC) will give protection for one or two additional years on major components.

# D13-MG (FE)

12.78 liter, in-line 6 cylinder

## Technical Data

### General

Engine designation	D13-MG
Configuration	in-line 6
Method of operation	4-stroke, direct-injected, turbocharged diesel engine with charge air cooler
Bore/stroke, mm)	131
Displacement, liter	12.78
Compression ratio	18.5:1

### Performance & fuel consumption

Engine speed	1500 rpm	1800 rpm	1500 rpm	1800 rpm
Crankshaft power HE/KC, kW	300	360	360	400
Crankshaft power RC, kW	289	341	349	381
Spec. fuel consumption HE/KC, g/kWh				
<b>at 50% load</b>	203	207	197	203
<b>at 75% load</b>	193	200	190	197
<b>at 100% load</b>	194	200	191	199
Recommended fuel to conform to	ASTM-D975 1-D and 2-D, EN 590 or JIS KK 2204			

10% overload available acc. to class requirements. Fuel temperature 40°C (104°F). Technical data according to ISO 3046 Fuel Stop Power with a tolerance ±4%. Fuel with a lower calorific value of 42700 kJ/kg and density of 840 g/liter at 15°C (60°F). Merchant fuel may differ from this specification which will influence engine power output and fuel consumption. The engine is certified according to IMO II, EU IWW for diesel electric propulsion.

<sup>1)</sup> Heat Exchanger cooled system (HE), <sup>2)</sup> Radiator Cooled system (RC), <sup>3)</sup> Keel Cooled system (KC)

# D13-MG (FE)

12.78 liter, in-line 6 cylinder

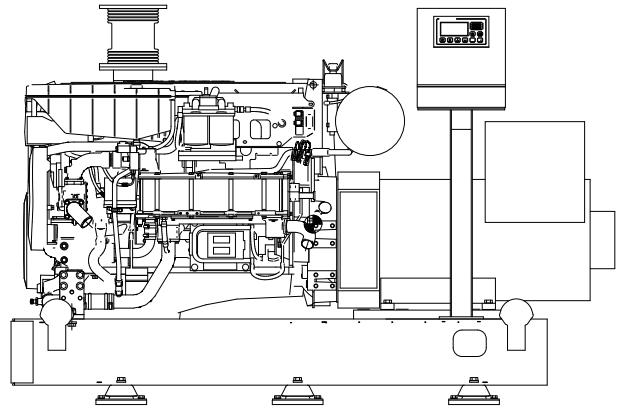
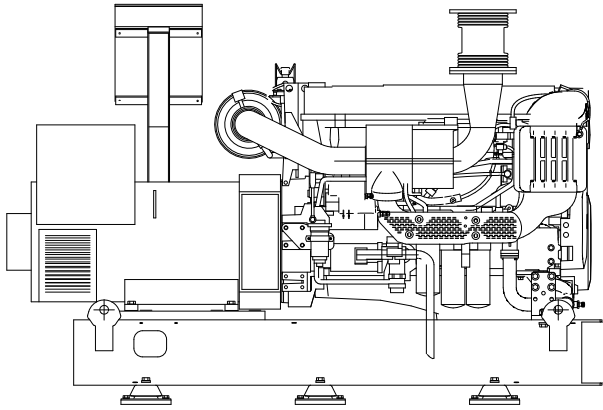

## Technical Data HE/KC Genset (Class F)

Power output at 1500 rpm 50Hz/400V

Engine / Generator	kWm	kWe	kVA
D13 MG / S4L1MF41	300	248	310
D13 MG / S5L1MC41	300	284	355
D13 MG / S5L1MD41	360	332	415

Power output at 1800 rpm 60Hz/440V

Engine	kWm	kWe	kVA
D13 MG / S4L1MF41	360	300	375
D13 MG / S5L1MC41	360	341	426
D13 MG / S5L1MD41	400	380	475

10% overload available according to class requirements.

Fuel temperature 40°C (104°F). Technical data according to ISO 3046 Fuel Stop Power and ISO 8665. Fuel with a lower calorific value of 42700 kJ/kg and density of 840 g/liter at 15°C (60°F). Merchant fuel may differ from this specification which will influence engine power output and fuel consumption.

## Technical Data HE/KC Genset (Class H)

Power output at 1500 rpm 50Hz/400V

Engine / Generator	kWm	kWe	kVA
D13 MG / S4L1MF41	300	272	340
D13 MG / S5L1MC41	300	286	358
D13 MG / S5L1MD41	360	344	430

Power output at 1800 rpm 60Hz/440V

Engine	kWm	kWe	kVA
D13 MG / S4L1MF41	360	324	405
D13 MG / S5L1MC41	360	343	429
D13 MG / S5L1MD41	400	383	479

10% overload available according to class requirements.

Fuel temperature 40°C (104°F). Technical data according to ISO 3046 Fuel Stop Power and ISO 8665. Fuel with a lower calorific value of 42700 kJ/kg and density of 840 g/liter at 15°C (60°F). Merchant fuel may differ from this specification which will influence engine power output and fuel consumption.

## Dimensions HE/KC L x W x H<sub>1</sub>/H<sub>2</sub> (mm), not for installation

D13 MG / S4L1MF41.....2739 x 1174 x 1814/1814

D13 MG / S5L1MC41..... 2811 x 1174 x 1814/1814

D13 MG / S5L1MD41 ..... 2811 x 1174 x 1814/1814

H<sub>1</sub> = Height including exhaust compensator

H<sub>2</sub> = Total genset height including control box

## Weight HE, kg

D13 MG / S4L1MF41.....3070

D13 MG / S5L1MC41..... 3175

D13 MG / S5L1MD41 ..... 3305

## Weight KC, kg

D13 MG / S4L1MF41..... 3030

D13 MG / S5L1MC41.....3135

D13 MG / S5L1MD41 .....3265

# D13-MG (FE)

12.78 liter, in-line 6 cylinder

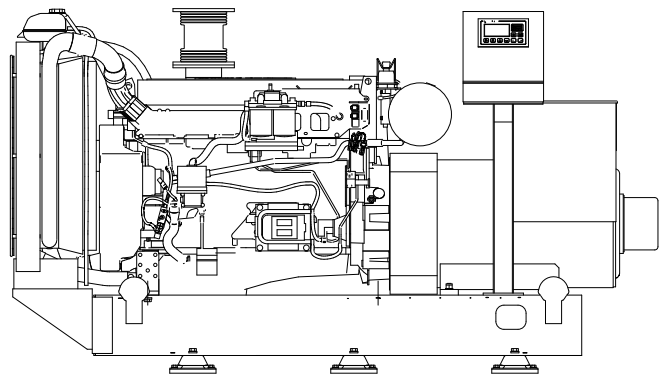
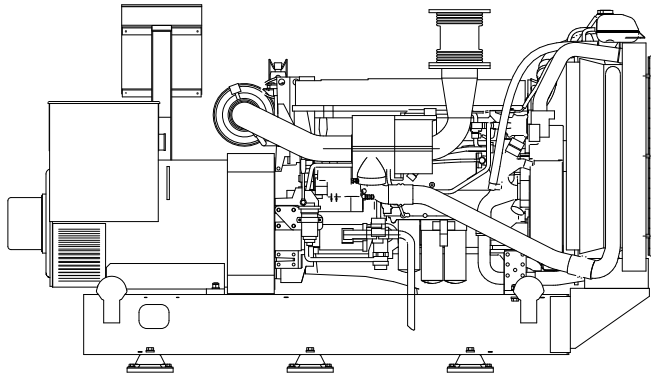

## Technical Data RC Genset (Class F)

Power output at 1500 rpm 50Hz/400V

Engine / Generator	kWm	kWe	kVA
D13 MG / S4L1MF41	289	248	310
D13 MG / S5L1MC41	289	275	344
D13 MG / S5L1MD41	349	332	415

Power output at 1800 rpm 60Hz/440V

Engine / Generator	kWm	kWe	kVA
D13 MG / S4L1MF41	341	300	375
D13 MG / S5L1MC41	341	322	402
D13 MG / S5L1MD41	381	360	450

10% overload available according to class requirements.  
 Fuel temperature 40°C (104°F). Technical data according to ISO 3046 Fuel Stop Power and ISO 8665. Fuel with a lower calorific value of 42700 kJ/kg and density of 840 g/liter at 15°C (60°F). Merchant fuel may differ from this specification which will influence engine power output and fuel consumption.

## Dimensions RC L x W x H<sub>1</sub>/H<sub>2</sub> (mm), not for installation

D13 MG / S4L1ME41.....	3057 x 1165 x 1811/1811
D13 MG / S4L1MF41.....	3147 x 1165 x 1811/1811
D13 MG / S5L1MC41.....	3219 x 1165 x 1811/1811
D13 MG / S5L1MD41 .....	3219 x 1165 x 1811/1811

## Weight RC, kg

D13 MG / S4L1ME41.....	3010
D13 MG / S4L1MF41.....	3080
D13 MG / S5L1MC41.....	3185
D13 MG / S5L1MD41 .....	3315

H<sub>1</sub> = Height including exhaust compensator  
 H<sub>2</sub> = Total genset height including expansion tank

## Technical Data RC Genset (Class H)

Power output at 1500 rpm 50Hz/400V

Engine / Generator	kWm	kWe	kVA
D13 MG / S4L1MF41	289	272	340
D13 MG / S5L1MC41	289	312	390
D13 MG / S5L1MD41	349	332	415

Power output at 1800 rpm 60Hz/440V

Engine / Generator	kWm	kWe	kVA
D13 MG / S4L1ME41	341	280	350
D13 MG / S4L1MF41	341	321	401
D13 MG / S5L1MC41	341	361	451

10% overload available according to class requirements.  
 Fuel temperature 40°C (104°F). Technical data according to ISO 3046 Fuel Stop Power and ISO 8665. Fuel with a lower calorific value of 42700 kJ/kg and density of 840 g/liter at 15°C (60°F). Merchant fuel may differ from this specification which will influence engine power output and fuel consumption.

# D13-MG (FE)

12.78 liter, in-line 6 cylinder

## Technical description

### Complete Genset

- High system efficiency as a result of system optimization of the complete Genset
- All used components of highest quality from well reputed suppliers
- Reinforced set dimensioned for high output and low sound level
- Mono-block engine/generator rigidly mounted on a common bed frame
- Engine directly coupled to generator via a flexplate
- Flexible mountings including welding plates mounted under the frame

### Engine and block

- Cylinder block and cylinder head made of cast iron
- One piece cylinder head
- Replaceable wet cylinder liners and valve seats/guides
- Drop forged crankshaft with induction hardened bearing surfaces and fillets with seven main bearings
- Four valve per cylinder layout with overhead camshaft
- Each cylinder features cross-flow inlet and exhaust ducts
- Gallery oil cooled forged aluminum pistons, three piston rings (keystone top ring)
- Senders for oil pressure (after filter), oil temp, oil pressure, oil level, fuel pressure, freshwater pressure, exhaust temp, crank-case pressure, speed crank and cam, boost pressure/temp, seawater pressure (not KC or RC cool.), coolant level, coolant temp
- Exhaust temperature indication

### Lubrication system

- Freshwater-cooled oil cooler integrated in cylinder block
- Twin full flow oil filter of spin-on type and single by-pass filter

### Fuel system

- Electronic Unit Injectors
- Gear-driven fuel pump, driven by timing gear
- Electronically controlled injection timing
- 5-hole high pressure injector nozzles
- Twin engine-mounted spin-on fine fuel filters with change over valve

### Turbocharger

- Dry twin entry turbocharger

### Heat Exchanger cooled system (HE)

- For seawater- and central-cooled Gensets
- Engine-mounted plate heat exchanger with expansion tank
- Belt-driven centrifugal freshwater pump
- Belt-driven rubber impeller raw water pump

### Keel cooled system (KC)

- 2-circuit cooling system
- Belt-driven centrifugal cooling water pump in HT circuit
- Engine mounted expansion tank in HT circuit
- Gear driven rubber impeller cooling water pump in CAC LT circuit

### Radiator cooled system (RC)

- For aircooled Gensets
- Polygroove belt-driven radiator fan
- Belt-driven centrifugal cooling water pump
- Air to air CAC (Charge Air Cooler)

### Generator

- 4-pole, brushless, AC marine generator
- Temperature rise class F and H
- Tropical insulation class H
- Stator winding as standard with short 2/3 pitch winding, ideal for non-linear load (thyristor load)
- Automatic Voltage Regulator (AVR) for accurate voltage regulation
- Permanent magnet mounted on generator for independent power supply to AVR
- Single bearing generator as standard
- Voltage available range up to 690V
- IP23 enclosure as standard
- Anti condensation heating

### Control System

- MCC a flexible and expandable control and monitoring system for classified installations. Incl. separate safety shutdown system
- Meets classification requirements of separate shutdown and monitoring system
- Easy to interface with leading suppliers of ship control systems
- Possibility to connect relays for remote control functions (potential free contacts)
- Classifiable by all major classification societies

## Optional equipment

### Engine

- Twin fuel pre-filters/water separator with change over valve
- Flexible exhaust compensator
- Cooling water connection bellows
- Electrical and air starting systems available individually or in parallel.
- Raw water pressure indication (only in combination with raw water pump)
- Engine heater 2000W
- Visco fan (only for RC gensets)

### Generator

- Air inlet filters according to IP23
- Air inlet louvres/filters according to IP44
- Parallel equipment mounted in generator
- Thermistors (1 or 2 per phase) mounted in generator for temperature measurement of windings in generator
- PT100 elements (1 or 2 per phase) mounted in generator for temperature measurement of windings in generator
- Double bearing generator (on request)
- PT100 elements mounted in generator bearings for temperature measurement

### Miscellaneous

- Dry exhaust silencer with or without spark arrester
- 110A alternator with integrated charging sensor
- Basic toolkit
- Spare parts according to classification recommendations

Contact your local Volvo Penta dealer for further information.

Not all models, standard equipment and accessories are available in all countries. All specifications are subject to change without notice.

The Genset illustrated may not be entirely identical to production standard Gensets.

Not all models, standard equipment and accessories are available in all countries. All specifications are subject to change without notice. The Genset illustrated may not be entirely identical to production standard Gensets.

Contact your local Volvo Penta dealer for more information regarding Volvo Penta engines and optional equipment/accessories or visit [www.volvopenta.com](http://www.volvopenta.com)



**AB Volvo Penta**

SE-405 08 Göteborg, Sweden  
[www.volvopenta.com](http://www.volvopenta.com)