

# TAD1650GE

16.12 liter, in-line 6 cylinder

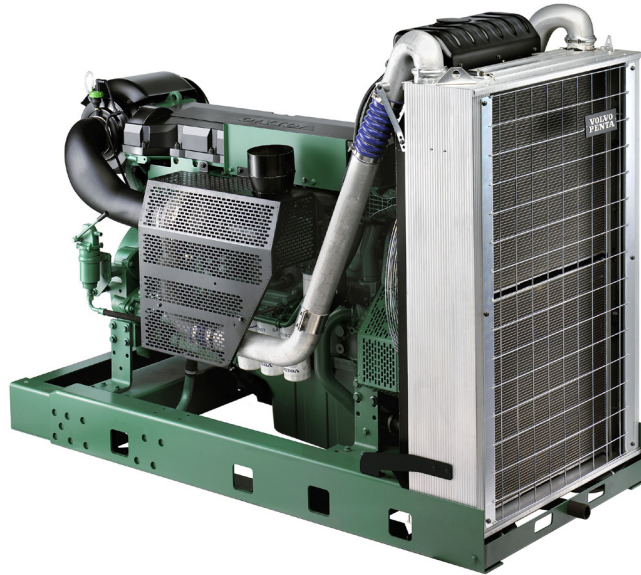

The TAD1650GE is a powerful, reliable and economical Generating Set Diesel Engine built on the dependable in-line six design.

### Energy efficiency and Economy

Through careful management of the combustion process, involving precise control of air movement and injection spray Volvo Penta has been able to achieve higher levels of efficiency than ever before. This has resulted in improved fuel economy and reduced exhaust emission levels that comply with current requirements and which will enable the engines to satisfy future legislation. Volvo Penta engines offer the highest kWh/Liter fuel, resulting in superior economy and performance.

### Durability & low noise

Designed for easy, fast and economical installation. Field tested to ensure highest standard of durability and long life. Well-balanced to produce smooth and vibration-free operation with low noise level. To maintain a controlled working temperature in cylinders and combustion chambers, the engine is equipped with piston cooling. The engine is also fitted with replaceable cylinder liners and valve seats/guides to ensure maximum durability and service life of the engine.

### Low exhaust emission

The state of the art, high-tech injection and highly efficient

charge air system with low internal losses contributes to excellent combustion and low fuel consumption. The engine is EPA/CARB Tier 3 & EU Stage 3A emission certified. These regulations are met by using V-ACT™ (Volvo Advanced Combustion technology). V-ACT includes a flexible high pressure fuel injection system, an air management system including an internal exhaust gas recirculation device and an enhanced electronic controller.

### Easy service & maintenance

Easily accessible service and maintenance points contribute to the ease of service of the engine.

- Volvo Penta Electronic management system
- Certified for US/EPA Tier 3 and EU Stage 3A
- High efficient cooling system
- Compact design
- Base engines as well as Gen Pac configurations
- Switchable between 1500/1800 rpm
- Excellent step load performance acc. to ISO 8528-5 G3 governing class
- Low operating cost

### 50 Hz / 1500 rpm

### 60 Hz / 1800 rpm

	Continuous power			Prime power			Standby power			Continuous power			Prime power			Standby power		
	kWm	kWe	kVA	kWm	kWe	kVA	kWm	kWe	kVA	kWm	kWe	kVA	kWm	kWe	kVA	kWm	kWe	kVA
TAD1650GE	295	278	347	393	369	462	433	407	508	329	310	387	439	413	516	483	454	568

### 50 Hz / 1500 rpm

### 60 Hz / 1800 rpm

Data Center Power	>300h running per year or non-reliable utility power in the country			≤300h running per year and reliable utility power in the country			>300h running per year or non-reliable utility power in the country			≤300h running per year and reliable utility power in the country		
	kWm	kWe	kVA	kWm	kWe	kVA	kWm	kWe	kVA	kWm	kWe	kVA
TAD1650GE	393	369	462	433	407	509	439	413	516	483	454	568

Generator efficiency (typical): 94%

kWm = kiloWatt mechanical, net with fan\*; kWe = kiloWatt electrical = kWm x Generator eff.; kVA = kiloVoltAmpere calculations based on a 0.8 power factor = kWe / 0.8  
 1 kW = 1 hp x 1.36; 1 hp = 1 kW x 0.7355

\*) According to technical data

# TAD1650GE

16.12 liter, in-line 6 cylinder

## Technical Data

### General

Engine designation.....	TAD1650GE	
No. of cylinders and configuration.....	in-line 6	
Method of operation.....	4-stroke	
Bore, mm (in.).....	144	(5.67)
Stroke, mm (in.).....	165	(6.50)
Displacement, l (in <sup>3</sup> ).....	16.12	(983.9)
Compression ratio.....	16.5:1	
Dry weight, engine only, kg (lb).....	1480	(3263)
Dry weight with Gen Pac, kg (lb).....	1910	(4211)

### Performance

	1500 rpm	1800 rpm
with fan, kW (hp) at:		
Prime Power	393 (534)	439 (597)
Standby Power	433 (598)	483 (657)
Fan power consumption, kW (hp)	9 (12)	15 (20)

## Fuel consumption

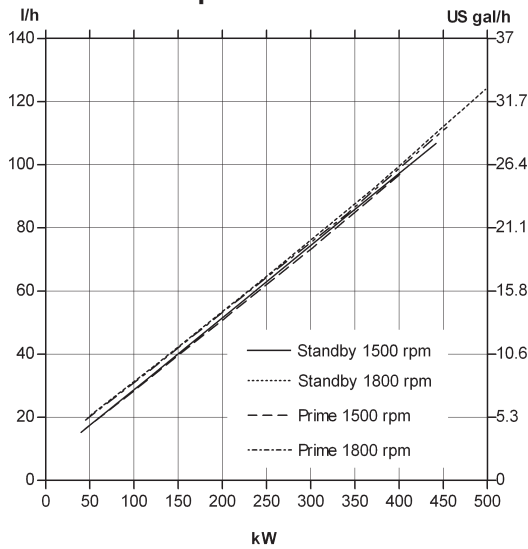

## Dimensions TAD1650GE

Not for installation

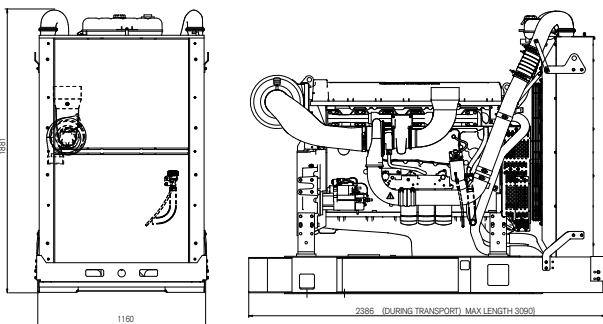

## Technical description

### Engine and block

- Cast iron cylinder block with optimum distribution of forces without the block being unnecessarily heavy.
- Wet, replaceable cylinder liners
- Piston cooling for low piston temperature and reduced ring temperature
- Tapered connecting rods for increased piston lifetime
- Crankshaft induction hardened bearing surfaces and fillets with seven bearings for moderate load on main and high-end bearings
- Case hardened and Nitrocarburized transmission gears for heavy duty operation
- Keystone top compression rings for long service life
- Viscous type crankshaft vibration dampers to withstand single bearing alternator torsional vibrations
- Replaceable valve guides and valve seats
- Over head camshaft and 4 valves per cylinder

### Lubrication system

- Full flow oil cooler
- Full flow disposable spin-on oil filter, for extra high filtration
- The lubricating oil level can be measured at start-up
- Gear type lubricating oil pump, gear driven by the transmission

### Fuel system

- Electronic high pressure unit injectors
- Fuel prefilter with water separator and water-in-fuel indicator / alarm
- Gear driven low-pressure fuel pump
- Fine fuel filter with manual feed pump and fuel pressure switch

### Cooling system

- Efficient cooling with accurate coolant control through a water distribution duct in the cylinder block. Reliable sleeve thermostat with minimum pressure drop
- Belt driven coolant pump with high degree of efficiency

### Turbo charger

- Efficient and reliable turbo charger
- Electronically controlled Waste-gate
- Extra oil filter for the turbo charger

### Electrical system

- Engine Management System (EMS), an electronically controlled processing system which optimizes engine performance. It also includes advanced facilities for diagnostics and fault tracing
- The instruments and controls connect to the engine via the CAN SAE J1939 interface, either through the Control Interface Unit (CIU) or the Digital Control Unit (DCU). The CIU converts the digital CAN bus signal to an analog signal, making it possible to connect a variety of instruments. The DCU is a control panel with display, engine control, monitoring, alarm, parameter setting and diagnostic functions. The DCU also presents error codes in clear text.
- Sensors for oil pressure, oil temp, boost pressure, boost temp, coolant temp, fuel temp, water in fuel, fuel pressure and two speed sensors.

## Rating guidelines

**CONTINUOUS POWER** is defined as being the maximum power which the generating set is capable of delivering continuously while supplying a constant electrical load when operated for an unlimited number of hours per year under the agreed operating conditions with the maintenance intervals and procedures being carried out as prescribed by the manufacturer.

**PRIME POWER** rating corresponds to ISO Standard Power for continuous operation. It is applicable for supplying electrical power at variable load for an unlimited number of hours instead of commercially purchased power. A 10 % overload capability for governing purpose is available for this rating.

**STAND-BY POWER** rating corresponds to ISO Standard Fuel Stop Power. It is applicable for supplying stand-by electrical power at variable load in areas with well established electrical networks in the event of normal utility power failure. No overload capability is available for this rating.

**DATA CENTRE POWER** is defined as being the maximum power which a generating set is capable of delivering while supplying a variable or continuous electrical load and during unlimited run hours. Depending on the sites to supply and the availability of reliable utility, the generating set manufacturer is responsible to define what power level he is able to supply to fulfil that requirement including hardware or software or maintenance plan adaptation.

## Power standards

The engine performance corresponds to ISO 3046, BS 5514 and DIN 6271. The technical data applies to an engine without cooling fan and operating on a fuel with calorific value of 42.7 MJ/kg (18360 BTU/lb) and a density of 0.84 kg/liter (7.01 lb/US gal), also where this involves a deviation from the standards. Ratings are based on ISO 8528. Engine speed governing in accordance with ISO 8528-5 G3.

Please note that products illustrated may differ from production models. Not all models and accessories are available in all markets, and standard equipment may vary between different markets. Every effort has been made to ensure that facts and figures are correct at the time of publication. However, Volvo Penta reserves the right to make changes without prior notice at any time.

Please contact your local Volvo Penta dealer for further information.



**AB Volvo Penta**

SE-405 08 Göteborg, Sweden  
www.volvopenta.com