

TWD1653GE

16.12 liter, in-line 6 cylinder

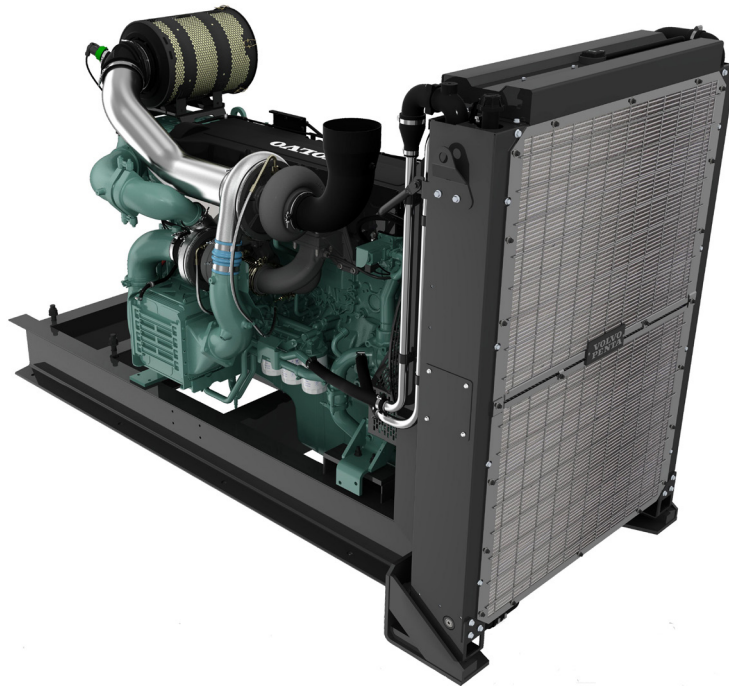

The TWD1653GE is a powerful, reliable and economical Generating Set Diesel Engine built on the dependable in-line six design.

Durability & low noise

Designed for easiest, fastest and most economical installation. Well-balanced to produce smooth and vibration-free operation with low noise level.

To maintain a controlled working temperature in cylinders and combustion chambers, the engine is equipped with piston cooling. The engine is also fitted with replaceable cylinder liners and valve seats/guides to ensure maximum durability and service life of the engine.

Low exhaust emission

The state of the art, high-tech injection and charging system with low internal losses contributes to excellent combustion and low fuel consumption.

The TWD1653GE complies with Indian emission legislation CPCB Stage II (Similar to EU Stage IIIA).

Easy service & maintenance

Easily accessible service and maintenance points contribute to the ease of service of the engine.

- Volvo Penta Electronic management system
- Complies with CPCB Stage II at 1500 rpm
- High efficient cooling system
- Compact design
- Base engines as well as Gen Pac configurations
- Excellent step load performance acc. to ISO 8528-5 3 governing class
- Low operating cost

50 Hz/1500 rpm

| Continuous power | | | Prime power | | | Standby power | | |
|------------------|-----|-----|-------------|-----|-----|---------------|-----|-----|
| kWm | kWe | kVa | kWm | kWe | kVa | kWm | kWe | kVa |
| 410 | 390 | 488 | 547 | 520 | 650 | 604 | 573 | 716 |

50 Hz/1500 rpm

| Data Center Power | >300h running per year or non-reliable utility power in the country | | | ≤300h running per year and reliable utility power in the country | | |
|-------------------|---|-----|-----|--|-----|-----|
| Engine | kWm | kWe | kVa | kWm | kWe | kVa |
| TAD1653GE | 547 | 520 | 650 | 604 | 573 | 716 |

Generator efficiency (typical): 95%

kWm = kiloWatt mechanical, net with fan according to technical data

kWe = kiloWatt electrical = kWm x Generator eff.

kVA = kiloVoltAmpere calculations based on a 0.8 power factor = kWe / 0.8

1 kW = 1 hp x 1.36; 1 hp = 1 kW x 0.7355

TWD1653GE

16.12 liter, in-line 6 cylinder

Technical Data

General

| | |
|--|---------------|
| Engine designation..... | TWD1653GE |
| No. of cylinders and configuration..... | in-line 6 |
| Method of operation | 4-stroke |
| Bore, mm (in.) | 144 (5.67) |
| Stroke, mm (in.) | 165 (6.50) |
| Displacement, l (in ³) | 16.12 (983.9) |
| Compression ratio | 16.5:1 |
| Wet weight, engine only, kg (lb)..... | 1780 (3924) |
| Wet weight with Gen Pac, kg (lb) | 2650 (5842) |

Performance

| | |
|--------------------------------|-----------------|
| with fan, kW (hp) at: | 1500 rpm |
| Prime Power | 547 (744) |
| Max Standby Power | 604 (821) |
| Fan power consumption, kW (hp) | 17 (23) |

Fuel consumption

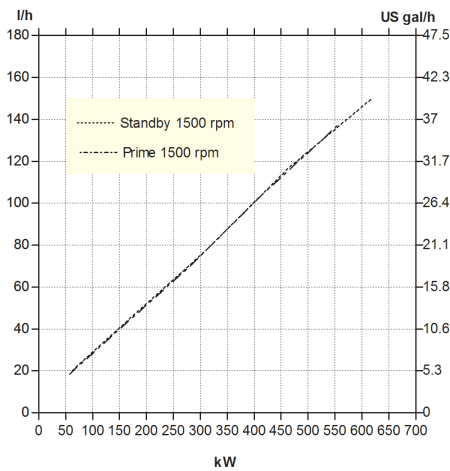

Dimensions TWD1653GE

Not for installation

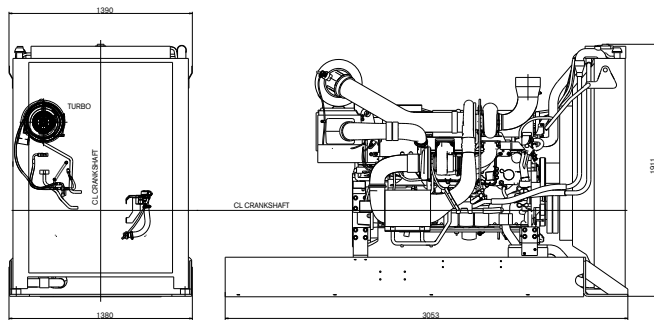

Technical description

Engine and block

- Optimized cast iron cylinder block with optimum distribution of forces without the block being unnecessarily heavy.
- Wet, replaceable cylinder liners
- Piston cooling for low piston temperature and reduced ring temperature
- Tapered connecting rods for reduce risk of piston cracking
- Crankshaft induction hardened bearing surfaces and fillets with seven bearings for moderate load on main and high-end bearings
- Case hardened and Nitrocarburized transmission gears for heavy duty operation
- Keystone top compression rings for long service life
- Viscous type crankshaft vibration dampers to withstand single bearing alternator torsional vibrations
- Replaceable valve guides and valve seats
- Over head camshaft and four valves per cylinder

Lubrication system

- Full flow oil cooler
- Full flow disposable spin-on oil filter, for extra high filtration
- The lubricating oil level can be measured during operation
- Gear type lubricating oil pump, gear driven by the transmission

Fuel system

- Non-return fuel valve
- Electronic unit injectors
- Fuel prefilter with water separator and water-in-fuel indicator / alarm
- Gear driven low-pressure fuel pump
- Fine fuel filter with manual feed pump and fuel pressure switch
- Fuel shut-off valve (option)

Cooling system

- Two water cooled charge air coolers
- Efficient cooling with accurate coolant control through a water distribution duct in the cylinder block. Reliable sleeve thermostat with minimum pressure drop
- Belt driven, maintenance-free coolant pump with high degree of efficiency

Turbocharger

- Efficient and reliable dual stage turbo chargers
- Intermediate charge air coolers for both turbo chargers
- Waste gate system for the high pressure turbo charger

Electrical system

- Engine Management System (EMS), an electronically controlled processing system which optimizes engine performance. It also includes advanced facilities for diagnostics and fault tracing
- The instruments and controls connect to the engine via the CAN SAE J1939 interface, either through the Control Interface Unit (CIU) or the Display Control Unit (DCU). The CIU converts the digital CAN bus signal to an analog signal, making it possible to connect a variety of instruments. The DCU is a control panel with display, engine control, monitoring, alarm, parameter setting and diagnostic functions. The DCU also presents error codes.
- Sensors for oil pressure, oil temp, boost pressure, boost temp, exhaust temp, coolant temp, water in fuel, fuel pressure and two speed sensors.

Rating guidelines

CONTINUOUS POWER is defined as being the maximum power which the generating set is capable of delivering continuously while supplying a constant electrical load when operated for an unlimited number of hours per year under the agreed operating conditions with the maintenance intervals and procedures being carried out as prescribed by the manufacturer.

PRIME POWER rating corresponds to ISO Standard Power for continuous operation. It is applicable for supplying electrical power at variable load for an unlimited number of hours instead of commercially purchased power. A 10 % overload capability for governing purpose is available for this rating.

STAND-BY POWER rating corresponds to ISO Standard Fuel Stop Power. It is applicable for supplying stand-by electrical power at variable load in areas with well established electrical networks in the event of normal utility power failure. No overload capability is available for this rating.

DATA CENTRE POWER is defined as being the maximum power which a generating set is capable of delivering while supplying a variable or continuous electrical load and during unlimited run hours. Depending on the sites to supply and the availability of reliable utility, the generating set manufacturer is responsible to define what power level he is able to supply to fulfil that requirement including hardware or software or maintenance plan adaptation.

Power standards

The engine performance corresponds to ISO 3046, BS 5514 and DIN 6271. The technical data applies to an engine without cooling fan and operating on a fuel with calorific value of 42.7 MJ/kg (18360 BTU/lb) and a density of 0.84 kg/liter (7.01 lb/US gal), also where this involves a deviation from the standards. Ratings are based on ISO 8528. Engine speed governing in accordance with ISO 8528-5 G3.

Please note that products illustrated may differ from production models. Not all models and accessories are available in all markets, and standard equipment may vary between different markets. Every effort has been made to ensure that facts and figures are correct at the time of publication. However, Volvo Penta reserves the right to make changes without prior notice at any time.

Please contact your local Volvo Penta dealer for further information.



AB Volvo Penta

SE-405 08 Göteborg, Sweden
www.volvopenta.com